

**TRUMPF**



TruBend Center

Get on the road  
to success





# Around the bends at high speed

Don't let curved components slow you down. You can win from start to finish with panel benders from TRUMPF, even with complex part geometries. The ultrafast programming saves you time right from the start. Minimum flange lengths, negative bends and all types of radii: you can handle any bend along the way with these all-rounders. Find out how this works on the following pages.

**Technology and parts** \_\_\_\_\_ **4–7**

How panel bending works and what advantages it offers.

**Functions and tools** \_\_\_\_\_ **8–15**

Become acquainted with the inner workings of the machines.

**Machines** \_\_\_\_\_ **16–21**

The semi-automatic TruBend Center 5030 and the fully automatic TruBend Center 7030.

**Automation** \_\_\_\_\_ **22–27**

Load and unload or connect storage: practical solutions at a glance.

**Making the switch** \_\_\_\_\_ **28**

How to get started with panel bending.

**Smart Factory** \_\_\_\_\_ **29**

We are at your side with special solutions and advice on networking.

**Bending expertise** \_\_\_\_\_ **30–31**

TRUMPF also offers many die bending machines.

**TruServices** \_\_\_\_\_ **32–33**

Our services give you all-round support.

**Technical data** \_\_\_\_\_ **34**

The figures at a glance.







# A solution for every edge

Many shapes are only possible thanks to the special construction type of TRUMPF panel benders with angle drives and advanced tools. These include minimum flange lengths, high boxes, small profiles, recesses, radius bends, and even multiple negative bends. Do you also have typical panel bending parts in your portfolio?

High repeatability with different bends: **Protective plate** made of mild steel (sheet thickness 1 mm)

High repeatability with different bends: **Drawer** made of mild steel (sheet thickness 0.6 mm)

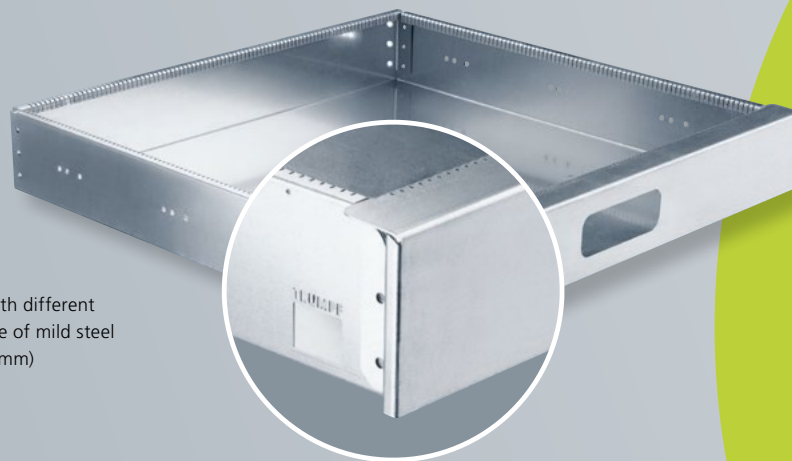

High-precision bending even with thicker sheets: **Outer casing** made of mild steel (sheet thickness 3 mm)

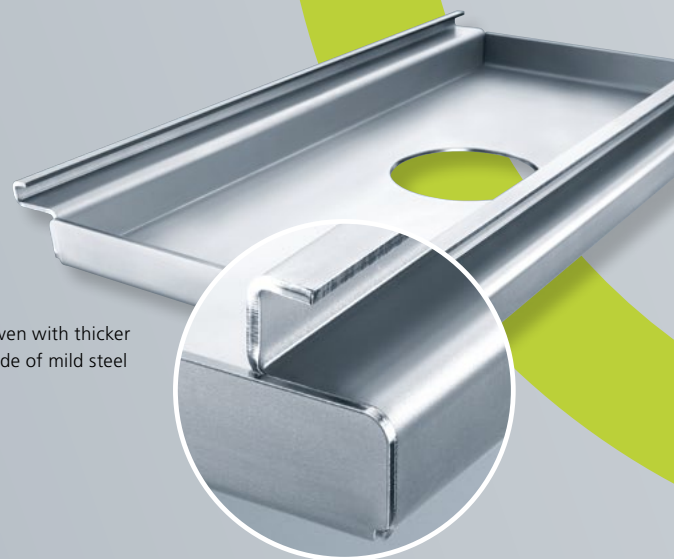

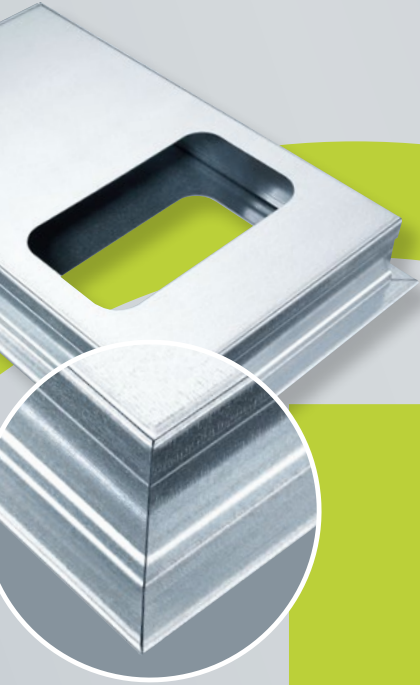

Produce plug connections with millimeter precision: Two-piece **container** made of stainless steel (sheet thickness 0.8 mm)



Short flange plus radius bend: **Drawer** made of stainless steel (sheet thickness 1 mm)

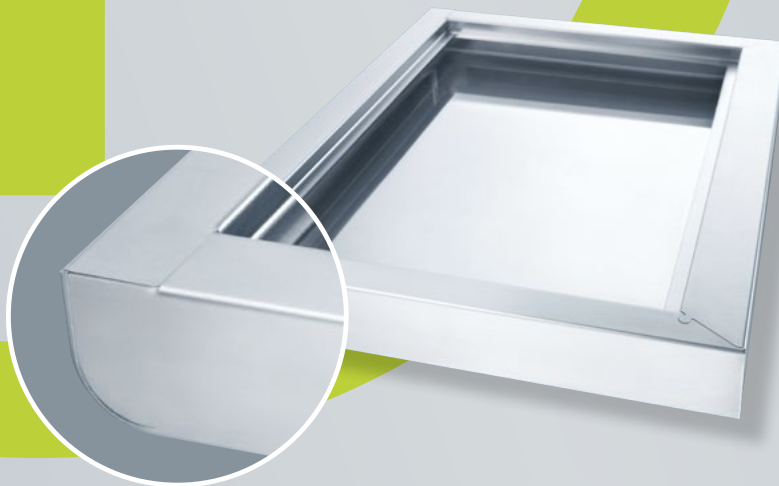

Short flange plus radius bend: **Screen casing** made of stainless steel (sheet thickness 1 mm)

# How panel bending works

From delicate cases to large tanks – with TRUMPF panel benders, you can create components for the widest range of applications and industries. And thanks to the integrated tool changer, it is easy to set up and highly productive.

This is how panel bending works: The sheet lies horizontally in the machine and is secured by blank holder tools. The upper and lower bending tools are mounted directly on the bending frame. The bend is created through the swivel movement of the bending tool. What's so special? Only the tool moves during bending. The component remains in the horizontal position and does not have to be guided.

- 
- **Is two to three times faster than die bending for many parts**
  - **Allows different radii on a single component with one tool**
  - **Creates design freedom, e.g. more roundings and unusual geometries**
  - **Produces perfect angles**



**“We have had a TruBend Center machine for almost 18 months, and it has completely changed our production. It delivers everything promised. The machine is the ideal fit for our product portfolio. The automation makes us faster, the quality is consistently good, and the system is very well received during customer visits. I would absolutely recommend it.”**

Phil Atkinson, Managing Director,  
BTS Facades and Fabrications, United Kingdom



More information  
about the TruBend  
Center 5030:  
[www.trumpf.com\\_s\\_  
trubend-center-series-  
5000\\_25](http://www.trumpf.com_s_trubend-center-series-5000_25)



More information  
about the TruBend  
Center 7030:  
[www.trumpf.com\\_s\\_  
trubend-center-series-  
7000\\_25](http://www.trumpf.com_s_trubend-center-series-7000_25)



# The key functions

Panel bending is not as common as die bending. But bending professionals never stop learning, they just learn more. Over the following pages we describe functions that set TRUMPF's panel benders apart.

## TecZone Fold: Ultrafast programming

Save yourself time right from the outset. TecZone Fold is the quickest and easiest programming for panel benders. Just a few clicks will get you to the finished part. TecZone Fold automatically suggests the ideal bending program – including 3D simulation and collision monitoring. If necessary, you can change or modify the program at any time manually.

Our user-friendly programming system creates programs offline. This helps you avoid downtime and allows you to program even small lot sizes and custom designs quickly and cost-effectively.

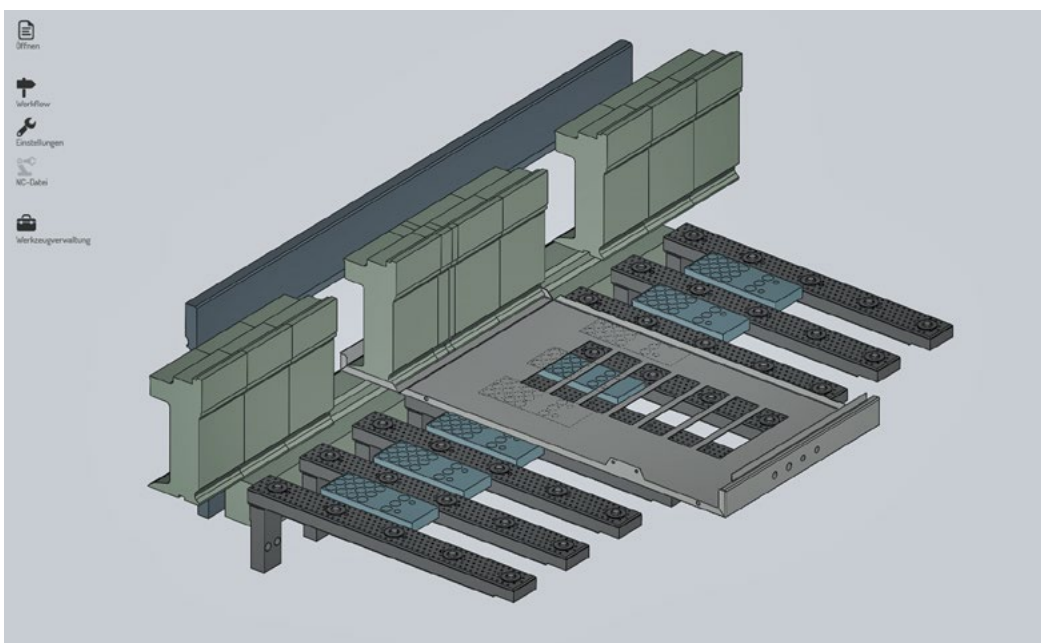

You can find more information about the TecZone Fold software here: [www.trumpf.com/s/teczone-fold](http://www.trumpf.com/s/teczone-fold)



With TecZone Fold, you are using the quickest and easiest programming for panel benders.



## Angle drive: Good from every angle

With its incredibly simple continuous-path control, the angle drive of the TruBend Center ensures maximum accuracy. The interaction of the two axes generates the swivel movement of the bending frame. This creates an ideal traverse path that goes easy on the surface of your component. The drive has a compact design and is particularly sturdy and low-maintenance. Thanks to an On-Demand Servo Drive, the hydraulic system runs only when the machine is bending. As a result, the drive saves energy, similar to the automatic start-stop function in a car.

**“With TecZone Fold, we create our NC data from STEP data in the office or right in the TruBend Center. Right from the start, the machine has been operated in two shifts – this was made possible also by the good training TRUMPF provided for our operators and programmers.”**

Dr. Steffen Albrecht, CEO,  
PreTec Schneidtechnologien, Germany

**“Programming with TecZone Fold is extremely easy and is usually done automatically by the software, without much intervention by the programmer.”**

Sebastian Winkler, technology,  
STEMA Metallleichtbau, Germany

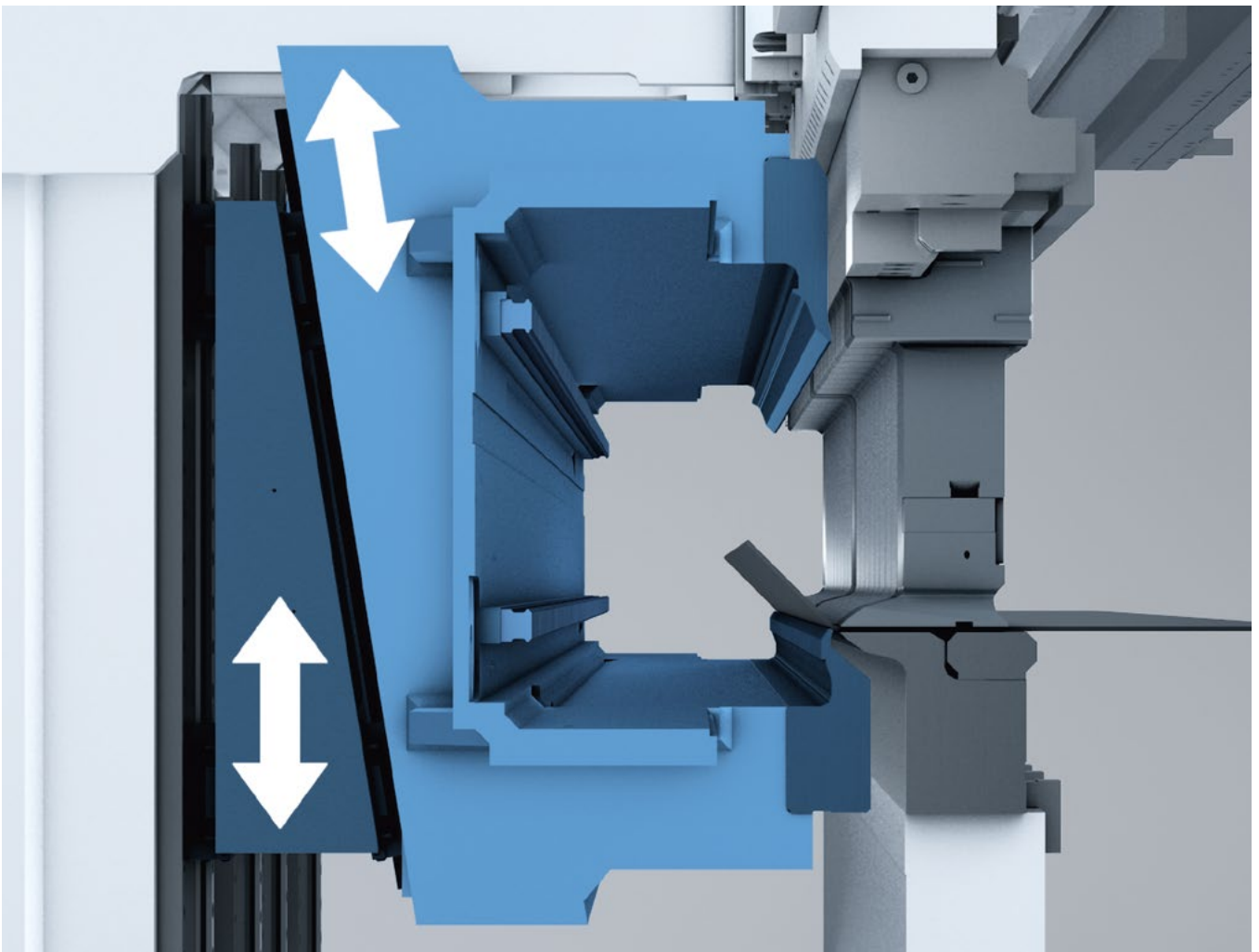

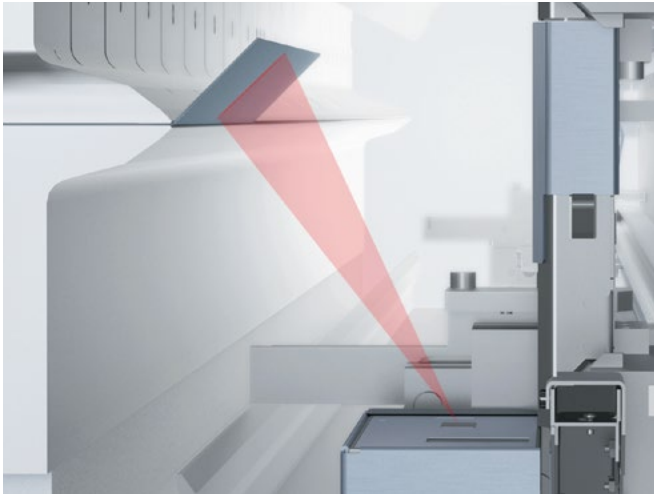

Precise angles thanks to ACB Laser.

## Angle: Not one degree too much

Use the world's first angle measuring system for panel benders: Optic and non-contact angle measurement with the ACB Laser has an accuracy of  $\pm 0.5^\circ$ . A laser projects a line onto the sheet and a camera detects the angle. To do this, a measuring unit moves to the correct position via CNC axis. Good to know: the system is tool-independent and easy to set up.

## Part manipulators: For maximum variety

The patented 2-axis part manipulator makes things possible – use it to bend a wide range of parts with panel bending. It holds the parts in place and moves them vertically and horizontally. Thanks to its vertical axis, it secures components in different positions and enables negative bends without catching. You can then, for example, manufacture components with several downward bends. You can also produce formed sections or openings in a reliable process.

When bending, an operator is usually responsible for rotating the parts. This is not the case with the TruBend Center 7030, which has a rotary part manipulator. It positions the sheet within the machine at a speed of up to 3,000 mm/s and thus significantly accelerates the bending process. In combination, the 2-axis and rotary part manipulator are far ahead of the competition. This is because they bend an enormous range of parts fully automatically. For example, you can produce narrow profiles highly productively.

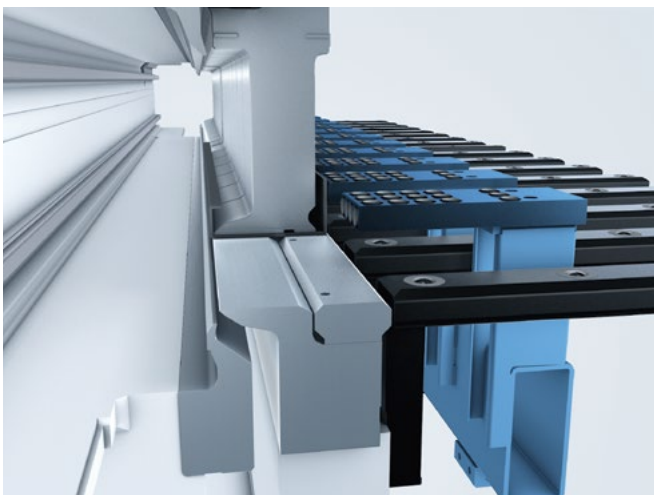

The height-adjustable 2-axis part manipulator makes an immense range of parts possible.

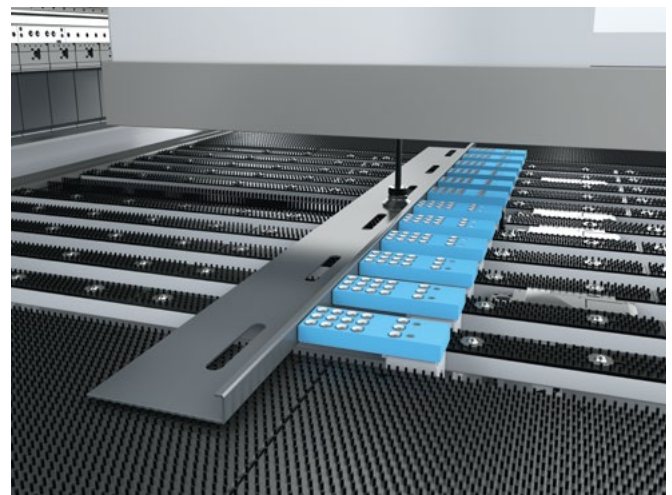

The team consisting of 2-axis and rotary part manipulator also bends narrow profiles fully automatically.



## Gripper modules: Everything in hand

Slippage impossible: Your machine handles the components safely by using different gripper modules. The 3-surface suction module has suction cups on the front, top and bottom

sides for this purpose. For components without a sufficient suction surface, magnetic or gripper modules position the sheet. The integrated sensors guarantee absolute precision.

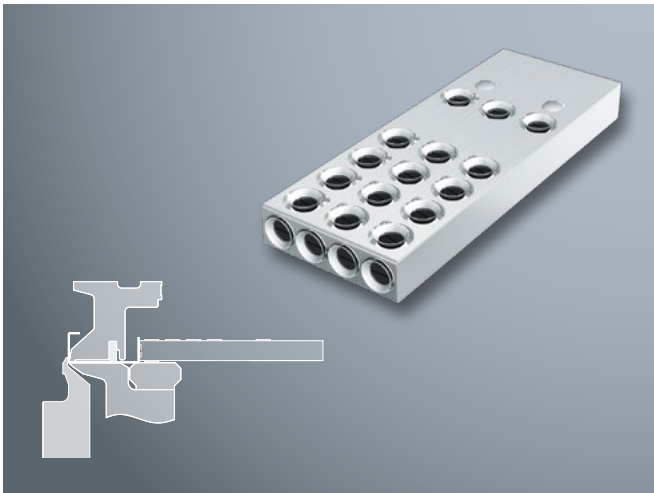

3-surface suction module

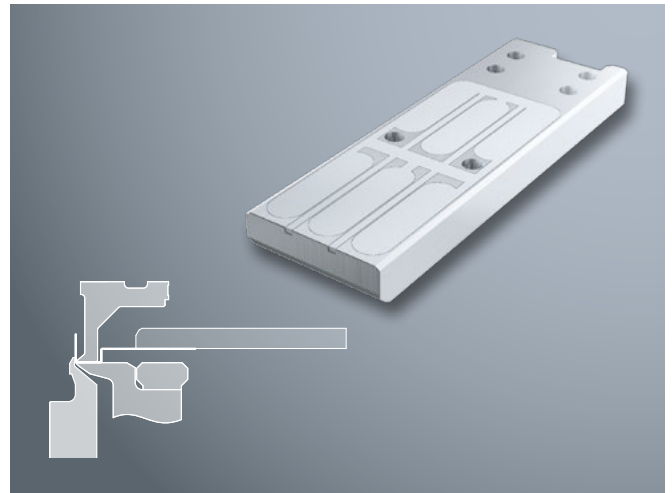

Magnetic module

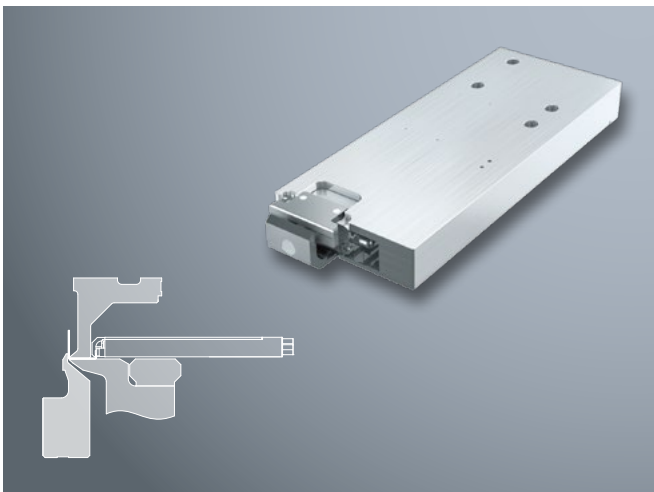

Vertical gripper module

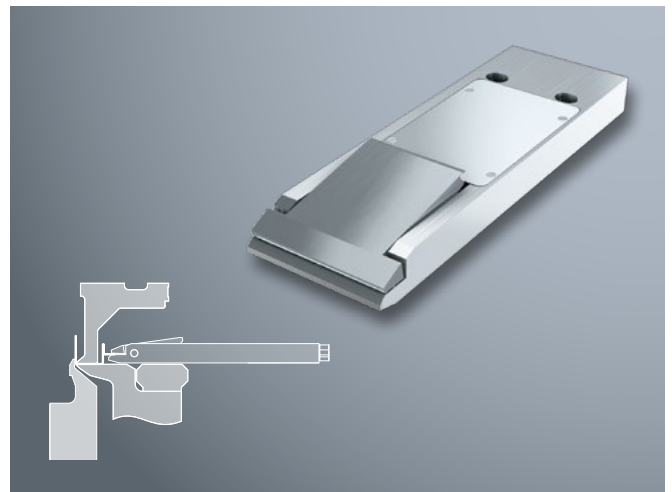

Horizontal gripper module

# The right tool automatically

With a wide range of integrated bending tools, TruBend Center machines master standard and special geometries. Their mechanically stable tools create extremely low-mark bends. Like the instruments of an orchestra, they are ideally tuned to each other so that you can produce a wide range of parts quickly.

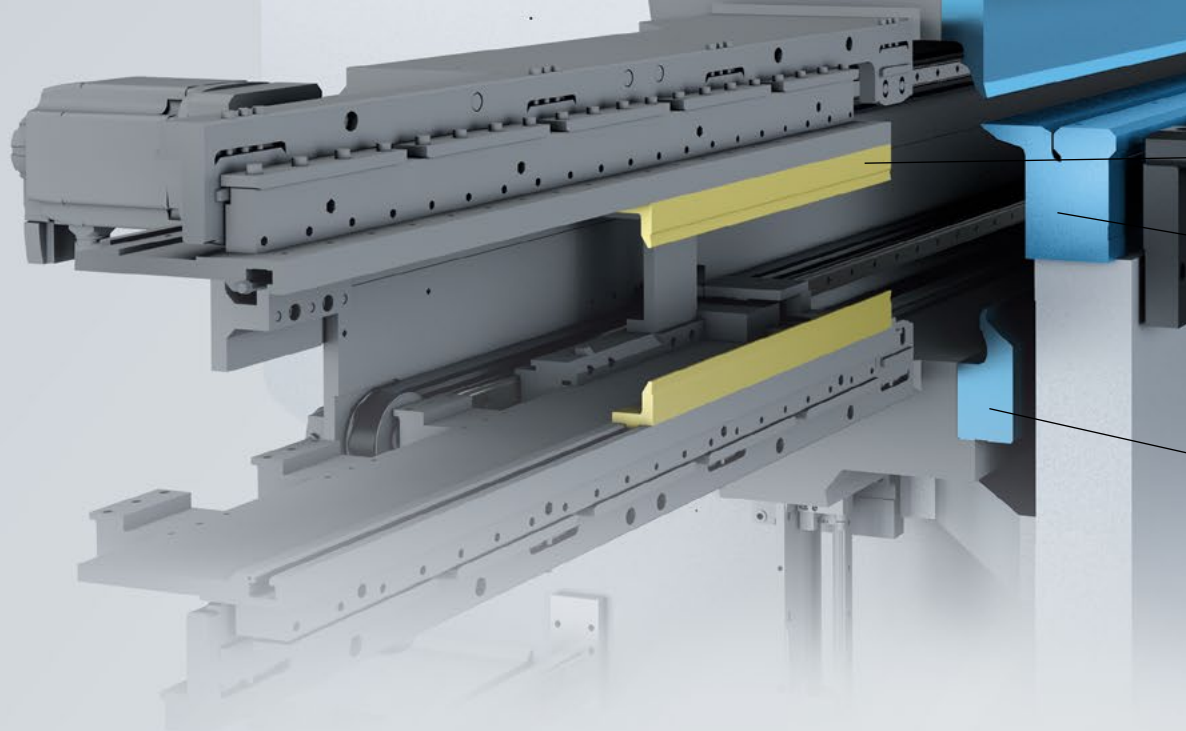



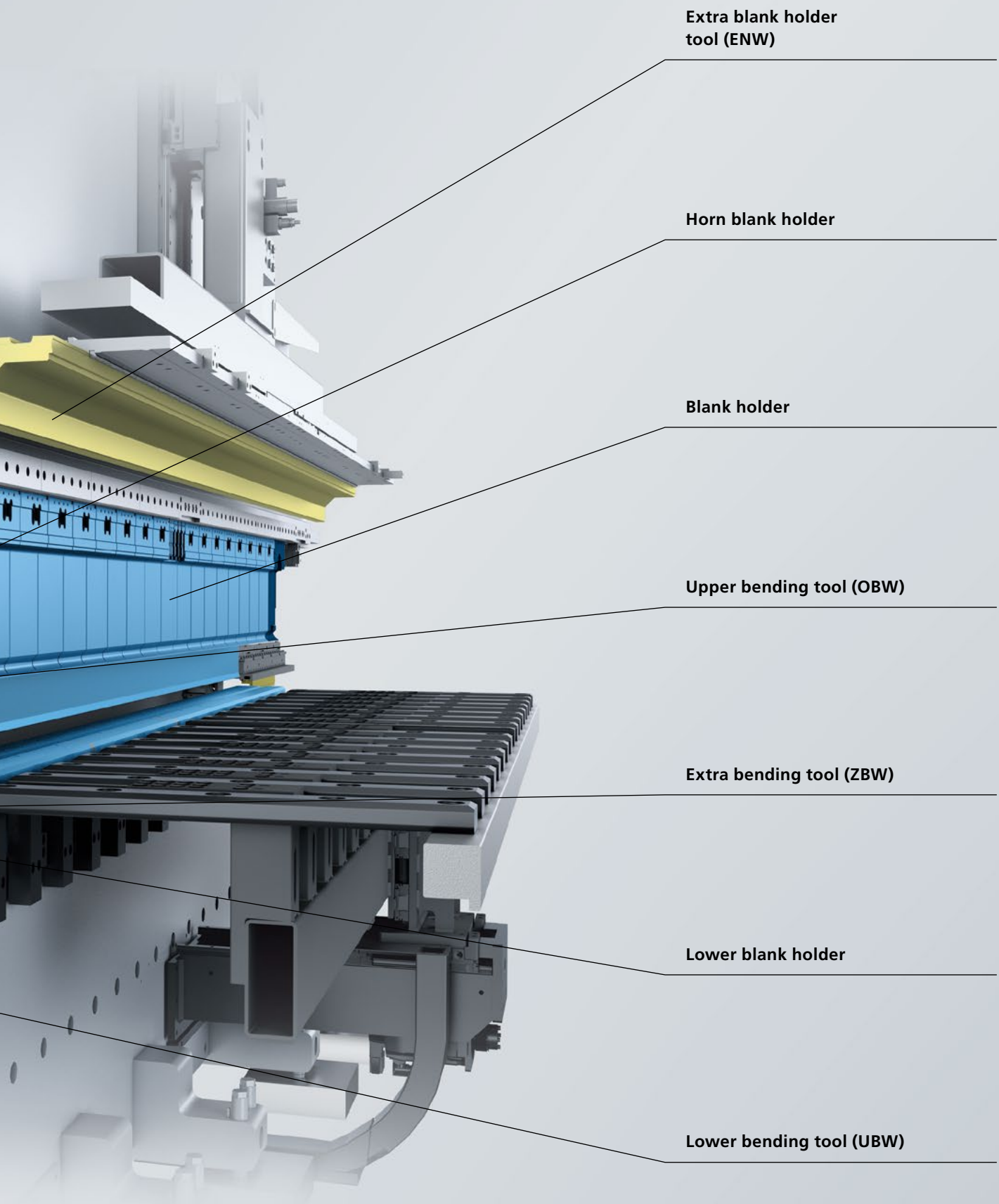

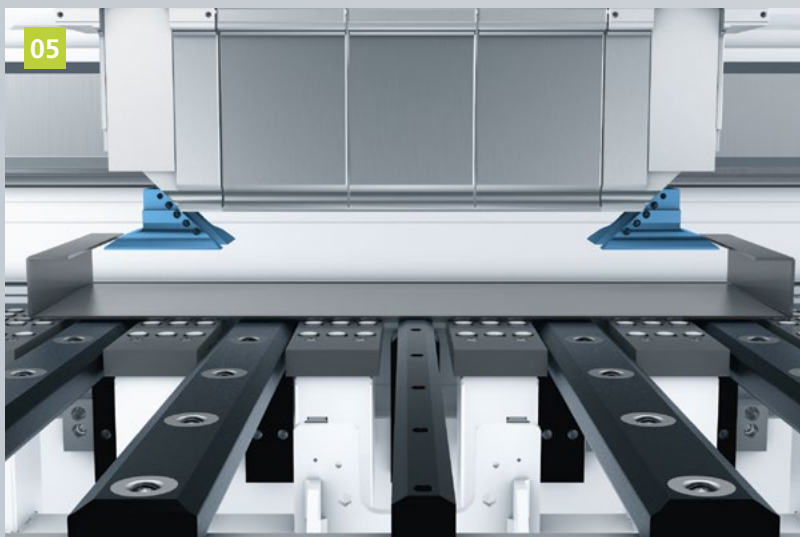
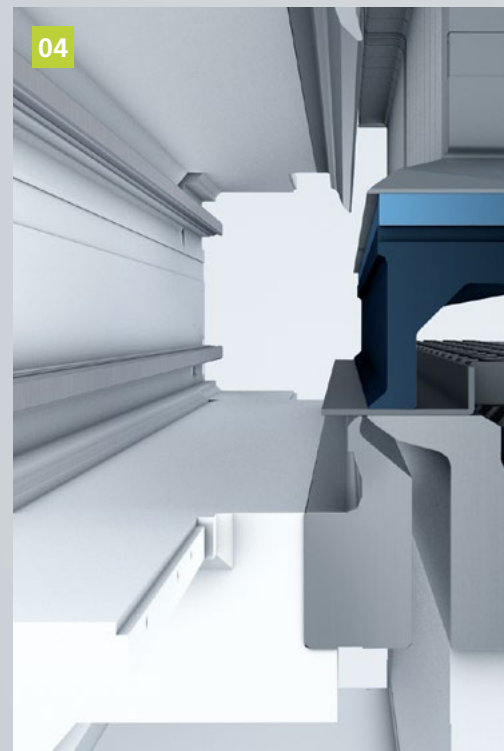
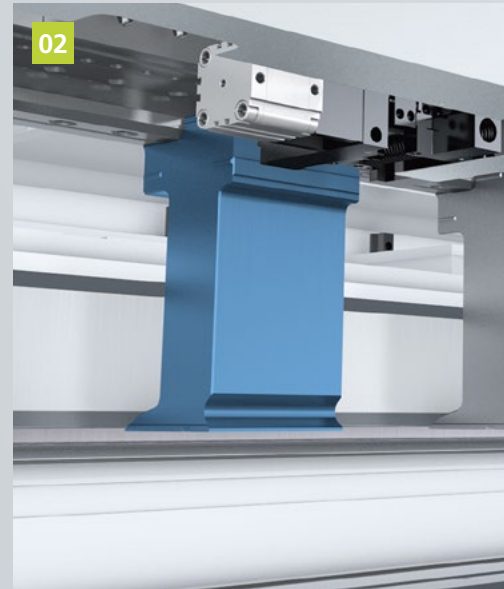
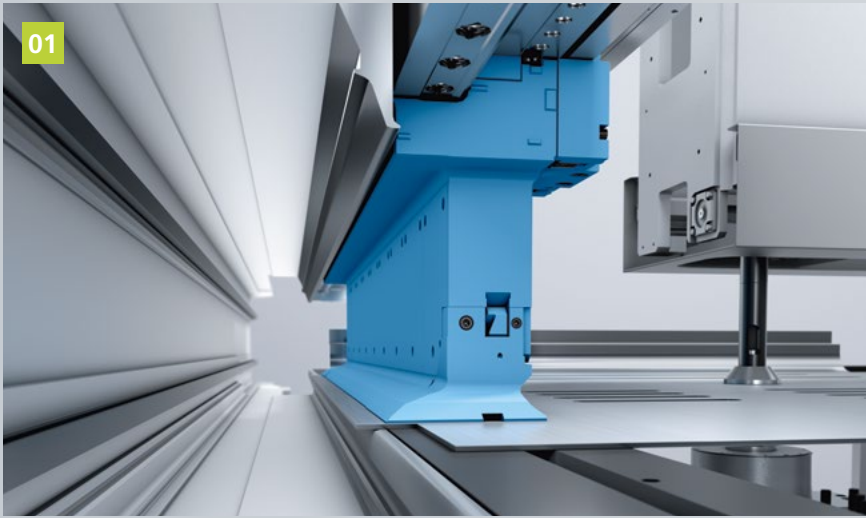



### 01 Blank holder

The blank holder is in continuous use during panel bending. Its function is to hold the blank securely in place during bending, ensuring its correct positioning.

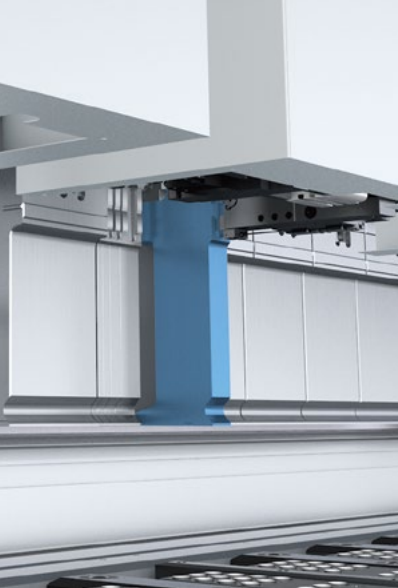

### 02 Automatic tool changer ToolMaster

Reduce setup times and prevent setup errors: The ToolMaster tool changer included in the standard package quickly pays for itself. It sets up the appropriate blank holder tools. It also significantly reduces your workload and allows you to manufacture individual parts cost-effectively yourself.

### 03 Extra bending tools (ZBW)

The bending of many part geometries is only possible with these, and they do it very productively. Extra bending tools come into play to bend tabs or offset bends. They are otherwise parked on the right and left side of the machine. When required, they automatically move to the right location of the bending frame and process the sheet.

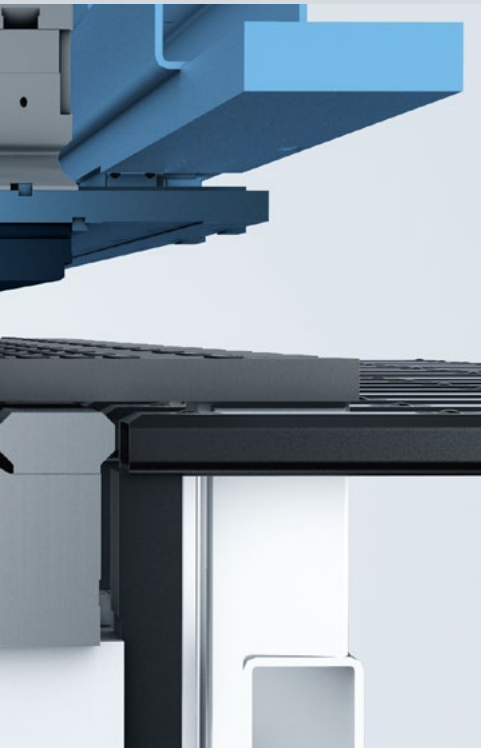

### 04 Extra blank holder tools (ENW)

Extra blank holders expand the range of application. They can be used to make, among other things, very narrow profiles. When they are required, the machine automatically swivels the extra blank holder tool in from above. You do not have to replace or modify the existing standard blank holder for this purpose. This allows you to use the entire potential of your machine.

### 05 Horn blank holder

These "horns" make it very easy to bend boxes with inner edges: They automatically extend and retract at an angle. This allows the blank holder to move downwards without causing a collision between the tool and the bend.

# Which one is right for you?

With TRUMPF panel benders, you can bend multidimensional part geometries quickly and cost-effectively. The semi-automatic TruBend Center 5030 is particularly ergonomic and easy to operate. With the fully automatic panel bending center TruBend Center 7030, you can maximize time savings: it rotates sheets independently and can be loaded and unloaded parallel to production.





**“One major advantage are the two axes on the part manipulator. They automatically lift parts with a negative bend. The optical angle assistant is just as useful: Even small angles can be corrected quickly and easily with the help of the camera. We also opted for this machine because of TRUMPF’s fast and reliable service.”**

Sebastian Winkler, technology,  
STEMA Metallleichtbau, Germany



# TruBend Center 5030

The panel bending team player reduces the operator's workload with semi-automatic top-class technology. Even on intricate tasks, it delivers first-class results and efficiently bends small lot sizes.

01

## Ergonomic and automated

For easy operation

02

## Cost-effective

Time savings of up to 60%



03

## Versatile

Bend any type of component



01

## Ergonomic and automated

For easy operation

The operator inserts the sheet horizontally, rotates it as necessary, and removes the finished part at the end. A single operator is sufficient for even large components. As only the tool moves during the bending process, the operator does not have to guide the component. The machine automatically changes the appropriate tool and independently handles all bends per edge.

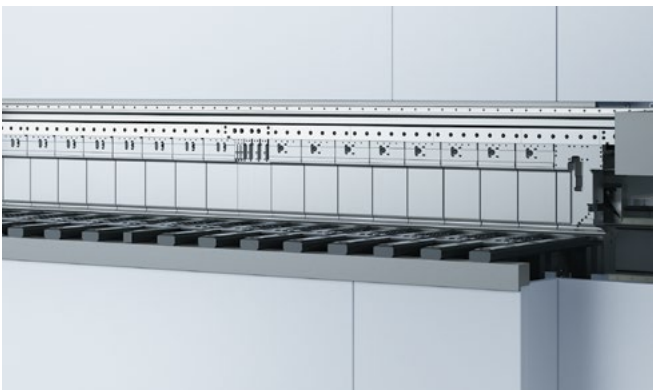

Only the tool moves during panel bending.

03

## Versatile

Bend any type of component

The semi-automatic panel bender masters multidimensional parts with formed sections, openings, negative bends, narrow profiles, and radii. Even very small components with minimal surface areas or extrusions close to the bending line can be expertly produced.



The TruBend Center can handle even the most complicated bends.

02

## Cost-effective

Time savings of up to 60%

The TruBend Center 5030 bends especially fast. For example, it can perform radius bends in up to five steps per second – without any reworking. Depending on the component, it offers time savings of up to 60% compared to die bending. The angle sensor ACB Laser guarantees exact angles, and the blank holder prevents markings on the sheet.



You can quickly bend radii with the machine without any reworking.



You can find more information about the TruBend Center 5030 here:

[www.trumpf.com\\_s\\_trubend-center-series-5000\\_25](http://www.trumpf.com_s_trubend-center-series-5000_25)



# TruBend Center 7030

The fully automatic bending center is unbeatable when it comes to high-level productivity. With its constancy and technical versatility, it reduces the workload of your entire team: its rotary part manipulator handles sheets perfectly and allows you to bend them in record time.

01

## Front gauge

Facilitates loading

02

## Rotary part manipulator

Moves your parts



03

## Loading gripper

Accelerates processing

04

## Part manipulators

Keep you in the fast lane



01

## Front gauge

Facilitates loading

The front gauge makes it easier to manually load your machine. Depending on the size of the component, it moves to the correct position. For components with inclined bending lines, it moves 50 mm forwards or backwards so that they can be inserted at an angle. It centers the components quickly and precisely. Then automatic processing at high speed can begin.

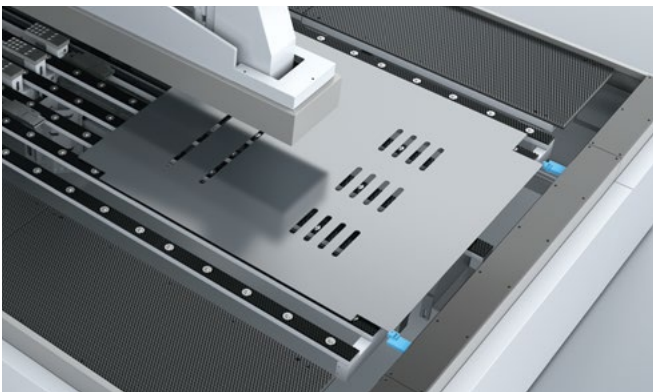

A component lies on the front gauge.

03

## Loading gripper

Accelerates processing

The loading gripper transports the sheet securely to the rotary part manipulator. A sensor system ensures that it stays in precisely the correct position. The loading gripper transfers the small parts to the 2-axis part manipulator. It accelerates processing of your parts with a traverse speed of up to 3,000 mm/s.



The component on its way into the processing area.

02

## Rotary part manipulator

Moves your parts

It gives the fully automatic bending center that crucial edge in terms of productivity: The rotary part manipulator automatically holds, rotates, and positions your sheets in the machine – much faster than by hand. The operator has less to do and only needs to load and unload.



The component is automatically moved faster.

04

## Part manipulators

Keep you in the fast lane

An unparalleled combination sets the machine apart: The height-adjustable 2-axis part manipulator moves your parts laterally and vertically, and the rotary part manipulator rotates them to any position you need. The TruBend Center 7030 is the only fully automatic panel bender that has this kind of combined system. The combination enables the unique range of applications of the machine at such speeds.



You can find more information about the TruBend Center 7030 here:

[www.trumpf.com\\_s\\_trubend-center-series-7000\\_25](http://www.trumpf.com_s_trubend-center-series-7000_25)



# Automated productive panel bending

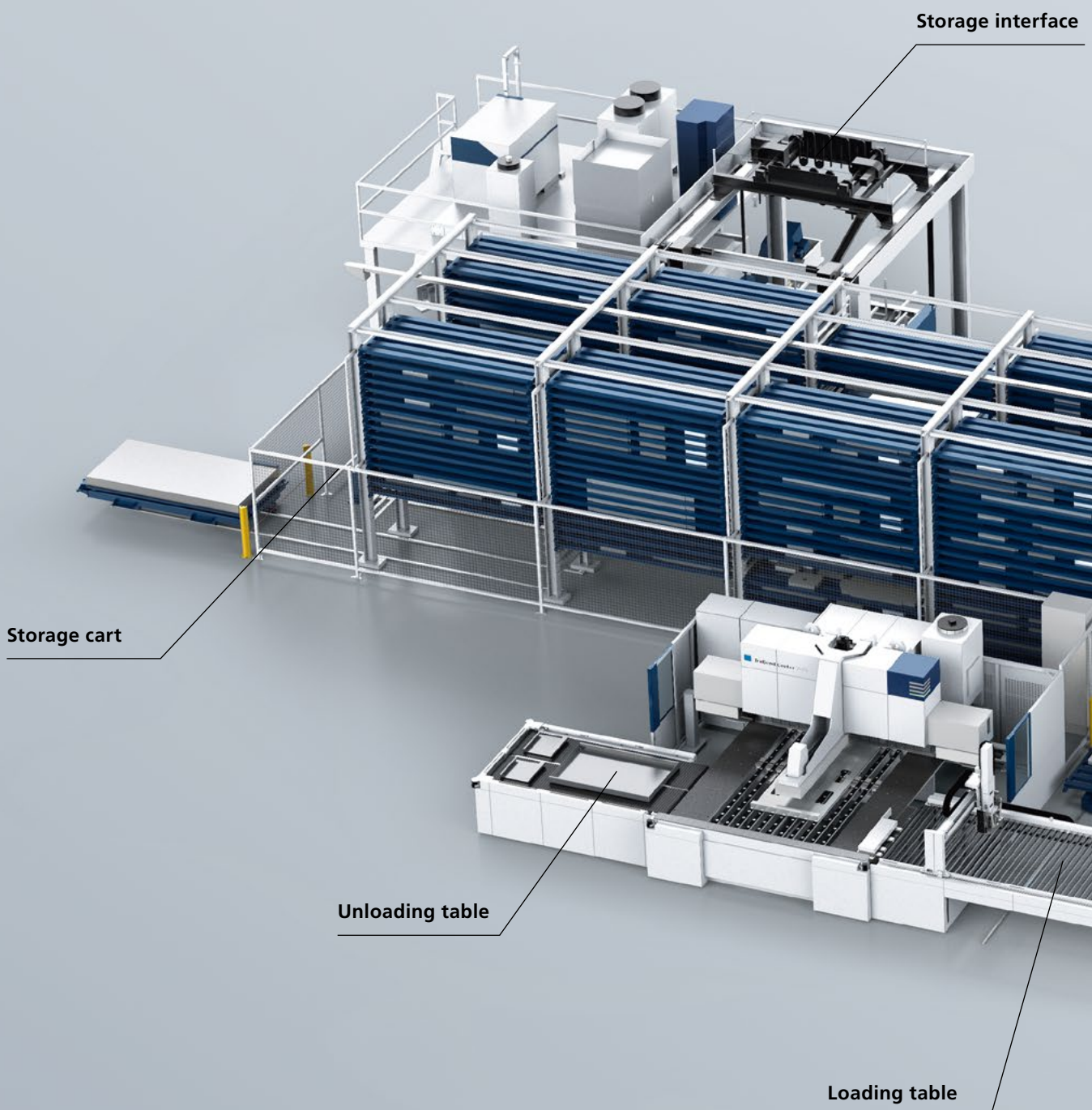



Why balance a heavy sheet by hand when it's easier with support? Automation saves the operator from having to haul heavy blanks and parts. And automation makes you more productive because you fully utilize the capacity of your panel bending center – especially in multi-shift operation. Whether you want to simply load and unload your machine automatically or completely automate the process with a large storage warehouse and storage cart: with the TruBend Center 7030, you have every option.

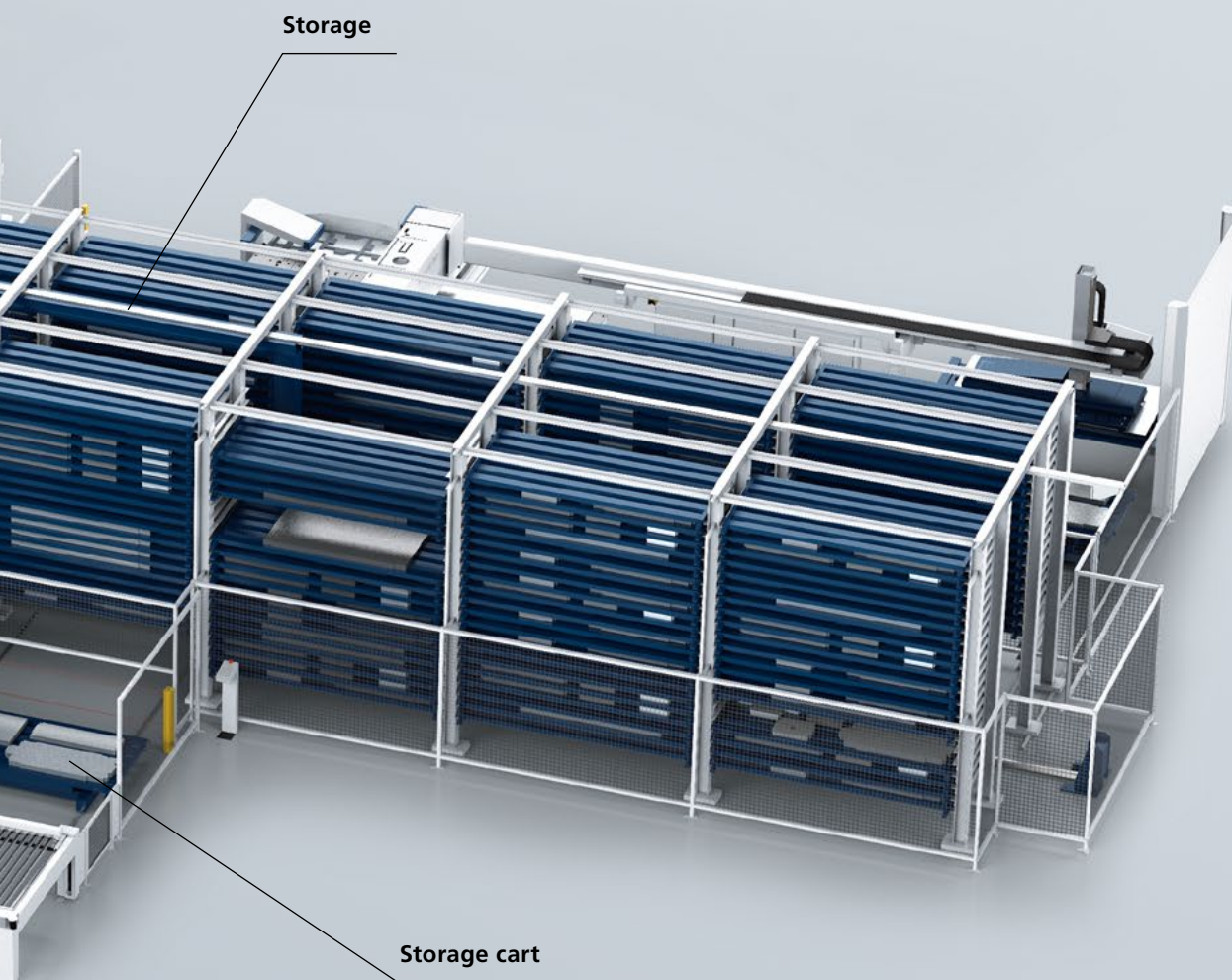

# Easy loading

With the right automation, your TruBend Center 7030 loads and unloads by itself. On the loading side, the loading unit picks up the blanks parallel to production and guides them to the processing step. Material flow and accessibility are optimized by using the loading cart where you can simply place blanks on pallets. For unloading, the machine uses two conveyor belts to buffer finished components. A robot interface is available for automatic unloading.

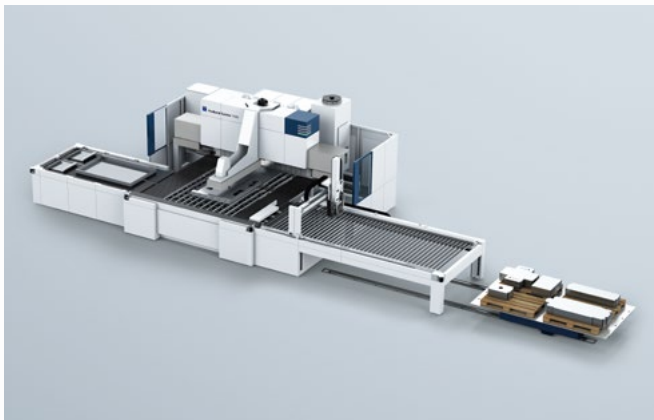

Installation version: You can position the loading cart at the side or front depending on your production requirements.

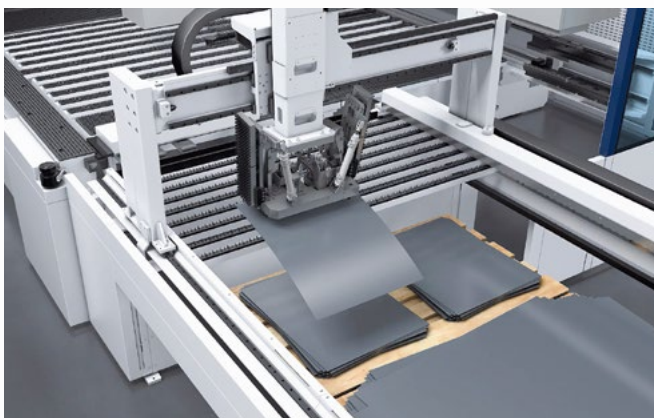

The suction gripper loads the TruBend Center 7030 automatically with large or small blanks while the machine is working.

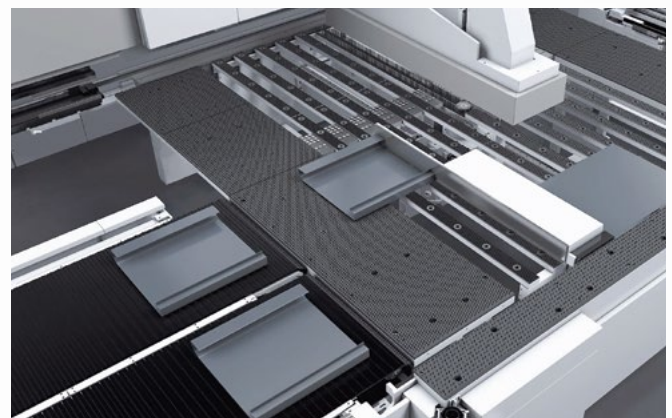

The two conveyor belts for unloading can be timed individually or synchronously. Finished parts are removed manually or by the robot.



### Unloading

The TruBend Center 7030 uses two conveyor belts for unloading. Finished components are then buffered individually or synchronously, depending on size. Your advantages: The machine unloads the parts scratch-free, offers storage space for smaller components, and works autonomously for longer than without an unloading table.

### Loading

The machine can pick up blanks from different stacks on the loading side – parallel to production. The blanks are centered and automatically fed into the machine for processing. The swiveling suction gripper loads small or large blanks without gripper change.

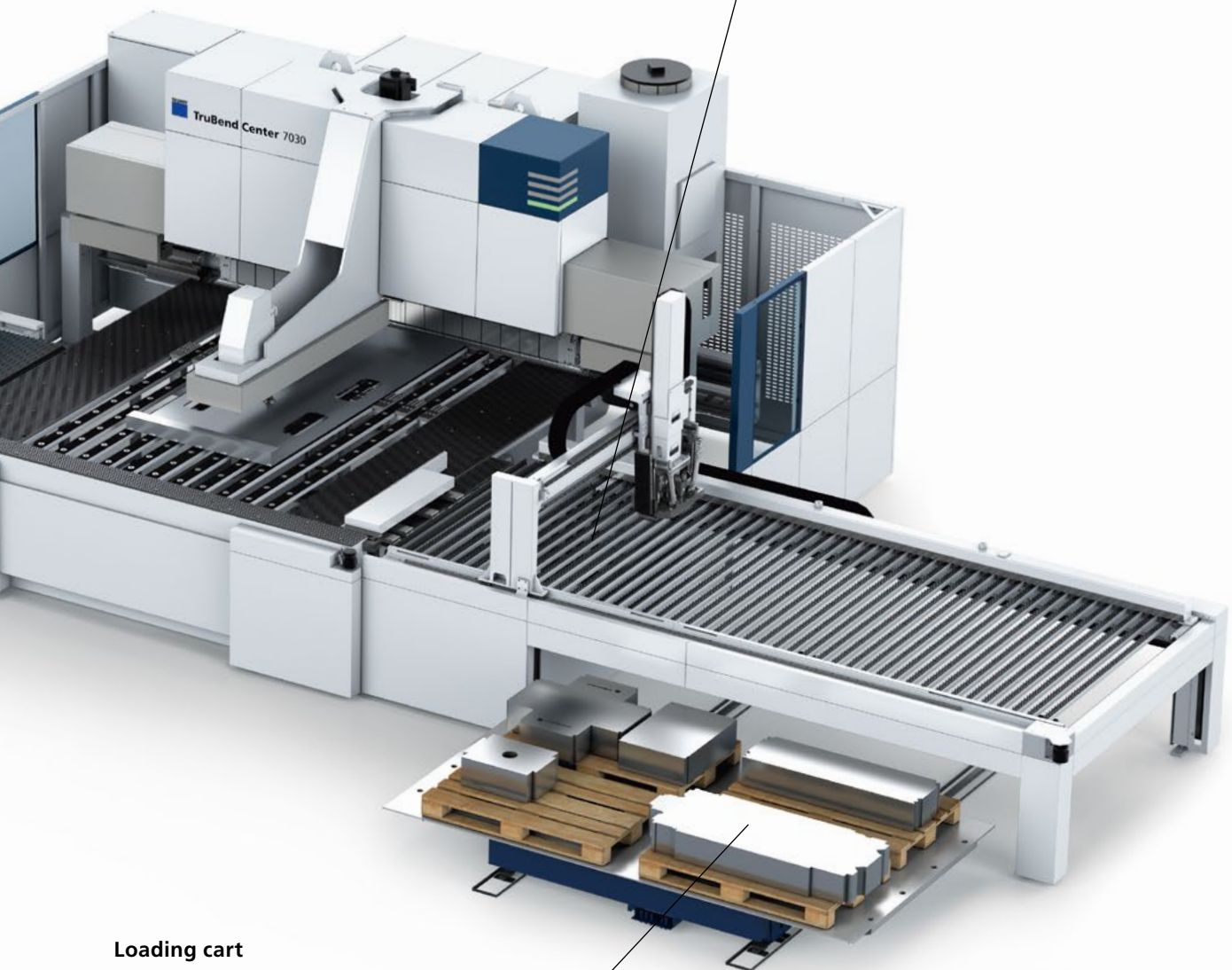

### Loading cart

The loading cart inserts blanks into the machine at the front or side. Its double sheet sensor, which also separates the sheets, ensures that the individual sheets are reliably fed into the machine. You can lay its travel rails above or embedded in the floor.

# Your storage – your flexibility

Is your production hall lined with sheet stacks? Save space, travel distances, and search times: With storage directly connected to your TruBend Center 7030. It streamlines your work processes and your material flow – and saves time and stress. TRUMPF's modular storage and logistics systems are modules for more flexibility in your production.

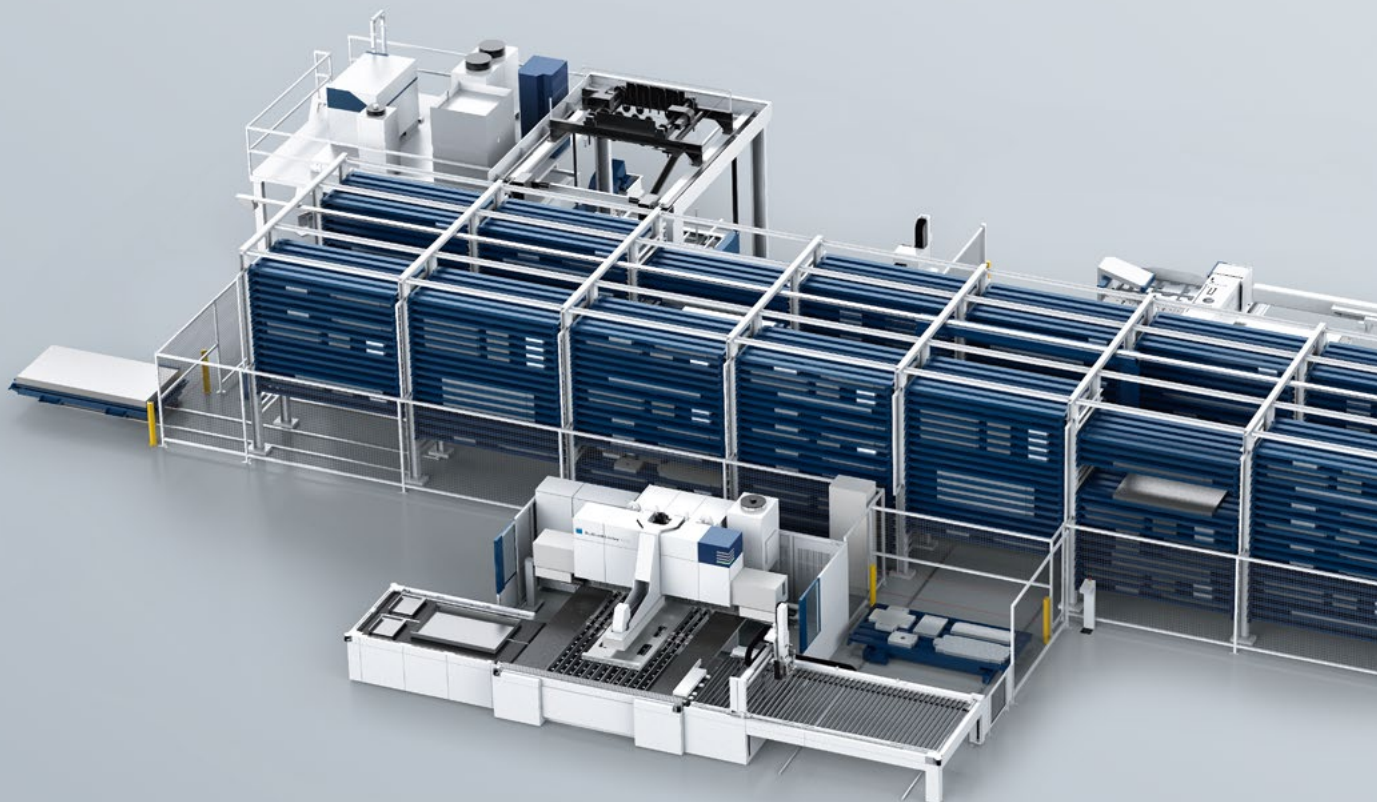



### TruStore 3000: Modular and compact

Whether storage height, shelves or capacity: You decide what you need. The most flexible storage system grows with your requirements. It reduces space requirements by up to 85% and can be expanded to a fully automatic system. A storage tower and pallet picker crane are part of the standard equipment. Simply connect the storage to your panel bending center – with just one unattended shift, you increase its capacity utilization by 100%.



### STOPA large-scale storage system

A STOPA large-scale storage system is more than just a material store – it is a complete logistics center for your production. It is tailored to your requirements in terms of length, width, height, and sheet size. Once set up, it offers plenty of space for unprocessed sheets, finished parts, scrap skeletons, and tube profiles. It supplies your TruBend Center 7030 24/7 when required – compared to conventional large-scale storage systems, it requires little maintenance and consumes up to 25% less energy.



# Making the switch with support

Panel bending is not the same as die bending, but it is easy to learn. Does the versatile technology also suit your range of parts? Find out – we will support you every step along the way.

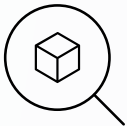

## Insight

Find out more about the TRUMPF panel benders to help determine whether the advantages it offers would be useful for you. Visit one of TRUMPF's demonstration centers or get advice from one of our product experts in your company.

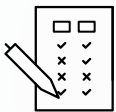

## Choice

Which panel bender is right for you? When choosing the productivity level, we work out your options so that you can make informed decisions.

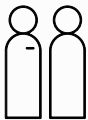

## Production support

To ensure that you can bend successfully from the outset, we are at your side throughout the installation and commissioning process. With the Initial Production Assistance option, a TRUMPF service engineer will assist you for several days. We also offer operator and programming courses – and are always available to answer your questions.

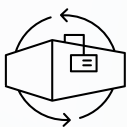

## Pre-owned machines

Pre-owned machines can also be purchased from us, refurbished and with warranties. If, for example, you want to replace a TruBend with a panel bender, we can help you sell it. We also offer tailored financing.



**When will you get on the road to success?**

Contact us at: [www.trumpf.com](http://www.trumpf.com)

# The best solution for your Smart Factory

The digital transformation is changing our working world. How can you respond to this increasing complexity in your production process? We can also develop special solutions tailored to your needs when required. And we will support you on your way to a Smart Factory. This is achieved by networking your production digitally and physically – from software, machines, and services to automation, storage, and logistic systems. Talk to us about the best production solution for your Smart Factory. You can find an example here:

---

## Your requirement

---

---

## Panel bending with punching and coil connection

---

A direct chain from the coil to the bent sheet using 1-piece flow.

---

---

## The solution

---

---

## Combine your coil system, punching machine and panel bender.

---

---

## Your benefits

- No need to program the coil system
- Coil system communicates with the punching machine as an external loading unit
- Machines can be linked as well as used individually
- Buffers compensate for different machine cycle times (for example, use of a BendMaster for the panel bender)



Discover the modular networking solutions from TRUMPF with **TruConnect:**  
[www.trumpf.com/s/smart-factory](http://www.trumpf.com/s/smart-factory)



# Concentrated bending expertise

Bending is our profession: As a technology leader in die bending, we offer you the largest portfolio on the market. Apart from die and panel bending, this portfolio includes large-format press brakes and fully automatic bending cells. Whether you bend delicate, complex, or oversized parts, the choice is yours. Ergonomics and exact angles are standard on all TRUMPF bending machines – to ensure that you are always in the right position when bending.



## Any component geometry

Regardless of whether it's thick, thin, large, or small parts – with bending machines from TRUMPF you can produce an enormous variety of parts. Due to the large range of TruBend machine variants, you can process any component geometry cost-efficiently and in top quality. You benefit from:

- Many tonnages and bending lengths
- A large material range from aluminum to HARDOX
- Precise positioning of your parts with 2-, 3-, 4-, 5-, or 6-axis backgauge systems

## Any part size

If you normally bend large parts, the option for "increased open height" might be of interest to you. The TruBend Series 7000 and the automatic TruBend Cell Series 7000 are in contrast specialized for small parts. Bend with flexibility:

- With a press force of up to 1,000 t
- Parts of up to 8 m in length
- Box heights of up to approx. 518 mm





The TRUMPF bending portfolio at a glance:  
[www.trumpf.com\\_s\\_bending-machines\\_25](http://www.trumpf.com_s_bending-machines_25)





# TruServices. Your Partner in Performance

To ensure your future success, you need services that definitely put you ahead of the pack in the long term. Whether that means creating the best conditions for successful production or optimally using your TRUMPF bending machine to adapt to changes with flexibility – together we will find ways to sustainably maximize your value creation. As a reliable partner, we will provide you with comprehensive solutions and service packages for your requirements – so that you can produce cost-effectively and at a constantly high level.

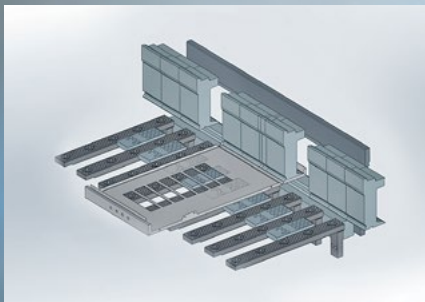

**EMPOWER:** If you wish to create the best conditions for successful manufacturing: We will support you. With the TecZone Fold software, it is easy to create your bending programs automatically – including 3D simulation and collision monitoring. The ultrafast programming makes your panel bender cost-effective even with small lot sizes and individual parts.



**IMPROVE:** If you want to gradually focus your manufacturing on maximum value creation: We will work together to reach your goal. Use our comprehensive training program to expand your knowledge and get a competitive edge. Our experienced trainers share their tips and tricks about bending machines with you and take you to the next level in the field of bending.

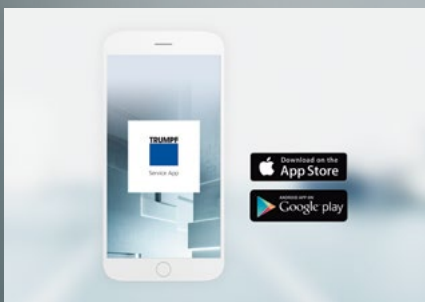

**SUPPORT:** If flexibility and availability of equipment in day-to-day operations are essential to you: We are at your side. The Technical Service and the TRUMPF service networks will assist you. Simply contact us; you can even do this via the Service app.





Financing

Training

Pre-owned Machines

Technical Service

Tools

Genuine Parts

Design and Programming Software

Process Optimization

Monitoring & Analysis

Product Enhancements

Value Packages

Service Agreements



Find out about our comprehensive complete package of helpful services:  
[www.trumpf.com/Services](http://www.trumpf.com/Services)





# Technical data

Here you can find an overview of the most important figures for the TruBend Center machines.

		TruBend Center 5030	TruBend Center 7030
Max. component size	mm	–	3120 × 1500
Max. component diagonal	mm	–	3460
Max. bending length	mm	3123	
Min. bending length	mm	200	
Min. bending depth (standard tool)	mm	145	
Min. bending depth (ENW <sup>(1)</sup> )	mm	40	
Max. box height	mm	220	
Max. material thickness for mild steel	mm	3	
Max. material thickness for stainless steel	mm	2,2	
Max. material thickness for aluminum	mm	4	
Min. material thickness	mm	0,5	

<sup>(1)</sup> Extra blank holder tool.

Subject to alteration. Only specifications in our offer and order confirmation are binding.



# Passion is what drives us

Whether it's production and manufacturing technology, laser technology, or material processing – we develop highly innovative products and services which are suitable for industry and absolutely reliable. We put everything we've got into giving you a compelling and competitive edge – expertise, experience, and a lot of passion.



Visit us on  
YouTube:  
[www.youtube.com/TRUMPFtube](http://www.youtube.com/TRUMPFtube)



#### Lasers for manufacturing technology

Whether on a macro-, micro-, or nanolevel – we have the right laser and the right technology to produce innovatively and cost-efficiently in every industrial application. Beyond the technology itself, we support you with system solutions, application knowledge, and consulting.



#### Power supplies for high-tech processes

From semiconductor manufacturing to solar cell production – with our RF and MF generators, the current for induction heating, plasma and laser excitation is given a defined frequency and power – with high reliability and repeatability.



#### Machine tools for flexible sheet and tube processing

Whether it's laser cutting, punching, bending, or laser welding – we offer tailor-made machines and automation solutions, including consulting, software, and services for all processes in flexible sheet metal processing – so you can reliably manufacture your products to exacting quality standards.



#### Industry 4.0

The TruConnect range of solutions links human and machine with information. It covers all steps in the production process – from the offer right through to the shipping of your parts.

TRUMPF is certified to ISO 9001  
(Find out more: [www.trumpf.com/s/quality](http://www.trumpf.com/s/quality))



TRUMPF Werkzeugmaschinen GmbH + Co. KG  
[www.trumpf.com](http://www.trumpf.com)