



**TRUMPF**



Laser systems

The answer  
to your  
manufacturing  
needs

# The perfect solution

Thousands of satisfied customers place their trust in machinery made by the world's leading technologist in laser material processing. Laser systems from TRUMPF give you the security of knowing you have chosen a highly flexible and extremely productive solution for your processing needs. We will support you every step of the way, from developing your application to choosing the right technology, components, and software – and we even offer comprehensive after-sales services. Together we can boost your productivity.

Your industry partner: We want to share our expertise with you.

**In good hands no matter  
what industry**  
4–7

In our Laser Application Centers, we work together with you to develop your process right from the very beginning.

**We can help you  
rise to the challenge**  
8–9

TRUMPF delivers sophisticated complete solutions that have proven their mettle.

**Everything from a single  
source**  
10–11

Diverse solutions for varied tasks: Together we will find the right one for your production line.

**Your application,  
our technologies**  
12–13

Best conditions for a successful production.

### **Condition Based Services 14–15**

Everything goes quickly with this software solution.

### **Easy programming 16–17**

An overview of the intelligent functions of all machine series.

### **Function overview 18–19**

Find out more about our product range here.

### **The answer to your manufacturing needs 20–49**

Our comprehensive services and unwavering support will give you a competitive advantage.

### **TruServices. Your Partner in Performance 50–51**

All the technical information you need at a glance.

### **Technical data 52–53**

# In good hands no matter what industry

What drives you drives us too. For many decades now, we have been offering customers from a wide range of industries help and advice on using laser technology. The knowledge we have acquired over this time gives us an edge that we aim to pass on to you: You can expect technology that is both state of the art and tailored to the specific needs and concerns of your industry. TRUMPF is always at the forefront of the latest trends, and is continually investing in the research and development of new technologies and potential applications to ensure we maintain this leading position in the future too.

## Anywhere and everywhere

Laser material processing has been an integral part of numerous vehicle sub-assemblies for many years now. Almost every component – from the drivetrain through to custom decorations – has had a laser involved in its manufacture.



See the versatility that working with laser tools offers across all industries:  
[www.trumpf.com/s/kecj9f](http://www.trumpf.com/s/kecj9f)

---

## Automotive industry

---

Laser technology has been a part of contemporary car manufacture for many years now. The automotive industry is a global one – and TRUMPF is a global company: Customers around the world can rely on premium service, high spare parts availability, and an expert team of industry managers and product managers who are supported by sales staff with encyclopedic knowledge of products and industries. Our industry expertise has been acquired over decades and will take your production process to the next level.



### Automobile body work

When working on car bodies, you always need very high speed and flexibility. With our laser systems, you can even process modern lightweight materials such as aluminum and hot-formed steel. With TRUMPF, you can bank on innovative, industry-adapted solutions for your welding, cutting, ablation, soldering and adhesive-preparation operations.



### Electromobility

Use laser technology to turn your ideas for high-performance, compact components into reality. Or benefit from new joining geometries for conductive metals and the ultrafast welding of batteries and electrical components – with minimal spatter and heat input.



### Lightweight design

Laser technology can open the door to modern-day lightweight construction, enabling you to process press-hardened and high-tensile steels, aluminum, fiber-reinforced materials, and hybrid material joins in a cost-effective way. Lasers even make it possible to use entirely new types of lightweight construction, such as intelligent structures or 3D-printed components, which will bring marked improvements to your product.



### Powertrain

Working with drives often takes you to the limits of possible joining technology. To machine your drive components you need stable, spatter-free processes and deep, flawless seams that are long-lasting and can withstand harsh conditions. The laser technology from TRUMPF makes all of this possible.

## Medical engineering

Nowhere is having reliable processes more important than in medical engineering: With TRUMPF you can count on ultraprecise, reproducible results without the need for reworking, plus highly flexible production from batch size 1. The laser light works contactlessly, meaning that sterility is assured at all times. Being marked with a laser ensures that parts are traceable in accordance with UDI standards, while 3D printing offers maximum customization of artificial hips or dentures.



## Electrics/electronics

Fast processes in fully automated production lines, high-precision processing and minimal exposure to heat for your workpiece: Laser systems from TRUMPF make achieving these things effortless. A laser also enables you to engrave an extremely high number of sensitive electronic components at the same time – without contact and free from wear.

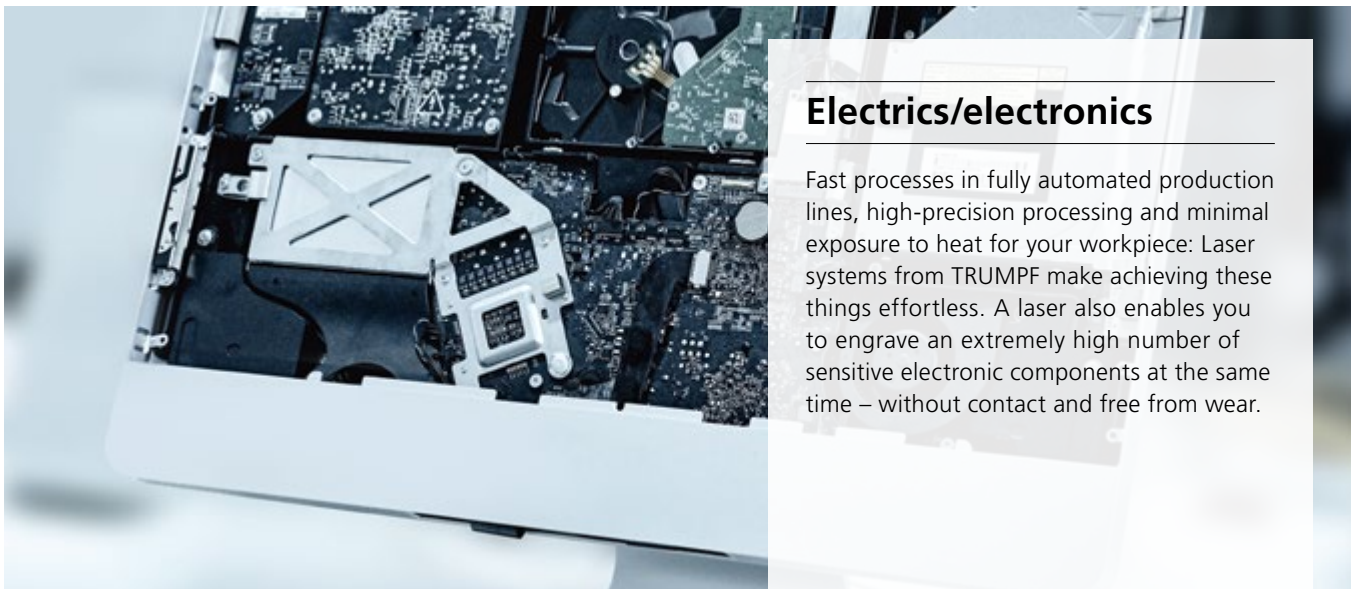

## Sheet metal working

Sheet metal working requires speed and flexibility. TRUMPF laser systems enable you to quickly and easily carry out retooling, welding, cutting, and deposition welding with a single machine, while also offering fast processing, an intuitive operating concept and assistance with application development.

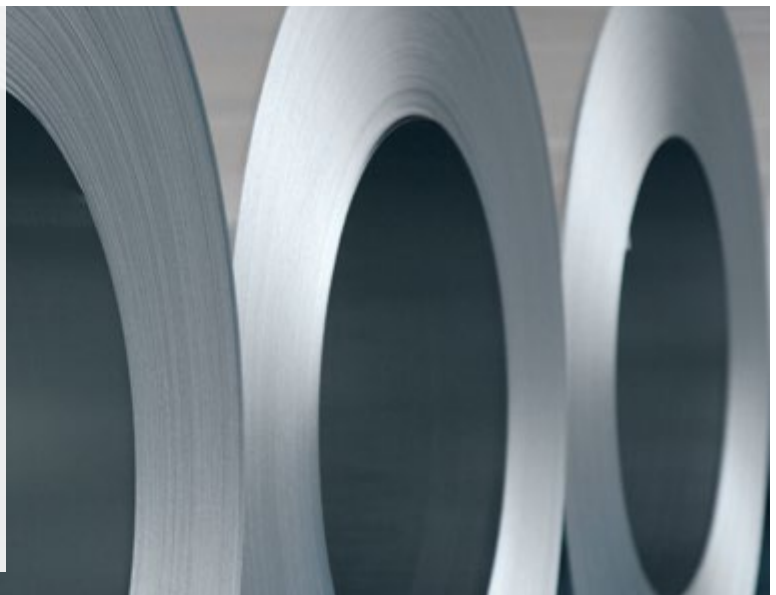



---

## Utility vehicles and transportation

---

Modern laser machines are consistently reliable and bring down the cost per part, for example when doing welding jobs or the laser cutting of automotive body parts. Procedures such as laser metal deposition help to repair components cost-effectively instead of having to replace them. In this regard, TRUMPF is a dependable partner for automatable solutions.

---

## Aviation and aerospace industries

---

From expensive certification processes and premium part quality to reliable reproducibility, the demands made in the aviation and aerospace industries are enormous. But with engineering from TRUMPF, you don't have to worry about meeting them: we offer cutting-edge technologies such as laser deposition welding and 3D printing to the highest standards, and we are here to help you with a global service team.



---

## Science

---

Are you conducting research into the properties of new or unusual materials? Or perhaps you're developing processing strategies for the industrial production line of the future? Then you need state-of-the-art laser systems that are reliable and offer flexible parameterization. TRUMPF is helping numerous universities and institutes to acquire new knowledge.



# We can help you rise to the challenge

Whether you know exactly what you need or you're looking for a custom solution, we will be there for you every step of the way. We are fascinated by lasers and all the possibilities they offer. In our Laser Application Centers (LAC) we are ready and waiting to assist you – no matter when, no matter where. This is because we want you to find the right partner in the right place who always has the right technologies for your needs.



"With our tailor-made service packages, we are there at your side in the midst of your running operation. Our comprehensive remote services offer quick, uncomplicated help when errors occur – and, thanks to TRUMPF Condition Based Services, even before they occur. We also offer a broad spectrum of consulting with training courses, product enhancements and application services provided directly at your site."

Benjamin Blocksdorf, Group Leader of Sales for Global Services, Ditzingen

"The industry management provides our customers with support long before they put the laser into operation. As early as the product development phase, our team of experts and key account managers provide step-by-step support for projects in industries like automotive and entertainment electronics. Working together with you, we develop tailor-made solutions to ensure you get the full potential of the laser technology in your production processes. In addition to current topics such as the electrification of vehicles or display technology applications, the further development and optimization of existing processes are very important to us."

Marc Kirchhoff, Head of Branch and Global Key Account Management, Ditzingen

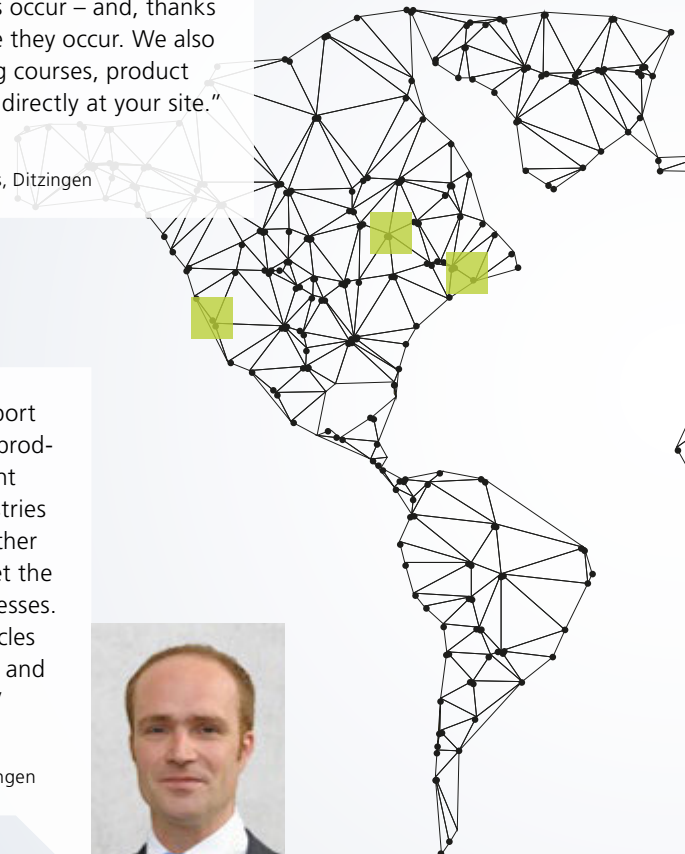



“TRUMPF helped us enter the market for 3D cutting high-strength steel grades. We received so many orders we soon had to purchase a second laser system.”

Gerardo Oaxaca, CEO of Superlaser & Fixtures, Puebla



Photo: Adam Wiseman

“TRUMPF’s technical expertise helped us finally find an automatable laser cutting solution. It’s done away with the need for two out of three work steps. Plus we can react more quickly to design changes in manufacture.”

Ulrich Nieweg, Head of Prefabrication/Tool Making at Zwilling J. A. Henckels AG, Solingen



Photo: Ralf Kreuels

“The demands on productivity and production control are constantly increasing in industry. In order to set new standards, we develop software and service packages that can predict downtimes or maintenance missions of the equipment. We work closely with our customers to precisely align product development with customer benefit.”

Florian Kiefer, Head of Product Management Services, Ditzingen



Find out more about how we can help you at our Laser Application Centers here: [www.trumpf.com/s/7smpvy](http://www.trumpf.com/s/7smpvy)

# Everything from a single source

TRUMPF gives you the security of knowing you have chosen a sophisticated and proven solution for your manufacturing system. Our numerous components – all of which we make ourselves – and our fully comprehensive global service make us a reliable partner for your production needs. You will also benefit from our knowledge of key issues for the future, such as Industry 4.0 and additive manufacturing.

## Everything for your machine

- Machine
- Laser
- Procedure-specific processing optics
- Sensor technology
- Software
- Custom solutions



## Everything for your manufacturing processes

- Automation solutions
- Construction of jigs and fixtures
- Part and powder management in additive manufacturing
- Laser network



### Diode insurance

With the diode insurance, you make your production costs more predictable and calculate your operating costs optimally. Benefit from increased certainty and cost transparency for your TRUMPF laser systems.

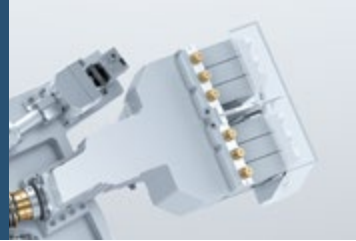

### Why choose TRUMPF laser systems?

- 1 Tailored solutions
- 2 Optimal for large-scale production and batch size 1
- 3 Consistently high component quality
- 4 Virtually warp-free processing
- 5 Highly precise results
- 6 No reworking needed
- 7 Maximum productivity minimizes cycle times
- 8 Process flexibility (cutting, welding, LMD)
- 9 Extremely robust and reliable
- 10 Maximum machine availability

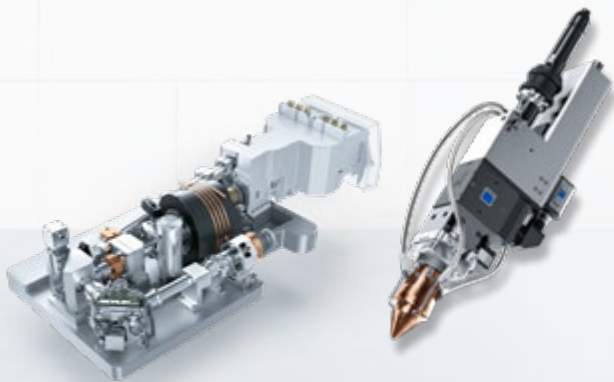

### TruServices. Your partner in performance

- Worldwide technical service
- Functional enhancements
- Monitoring and analysis
- Training
- Application advice



### The best complete solution for your manufacturing process

We place extremely exacting demands on our products in terms of their technology, engineering, quality, and usability in practice. We guarantee you won't fail to notice this.





Find out more about what lasers can do and how you could use laser technology in your work here:  
[www.trumpf.com/s/k4ivz1](http://www.trumpf.com/s/k4ivz1)

	TruLaser Cell 1100	TruLaser Cell 3000	TruLaser Cell 5030	TruLaser Cell 7040	TruLaser Cell 8030	TruLaser Station 7000	TruMark Station 3000	TruMark Station 5000/7000	TruPrint 1000/2000/3000/5000
<b>Welding</b>	■	■	■	■		■			
<b>Deposition welding</b>		■		■					
<b>Plastic welding</b>						■			
<b>Cutting</b>		■	■	■	■				
<b>Drilling and removing material</b>		■*						■	
<b>Hardening</b>		■*							
<b>Generating</b>		■		■					
<b>Marking</b>							■	■	
<b>Metal 3D printing</b>									■

\* Upon request.



# Condition Based Services

Would you like to sharpen your competitive edge? Digital networking offers numerous advantages: you see more, know more, and get the best out of your laser systems and your overall production. Condition Based Services already provide you with a full overview concerning the conditions of the beam source in your laser system. Additionally, TRUMPF Technical Service experts and algorithms support you in the timely detection and prevention of unplanned idle states.

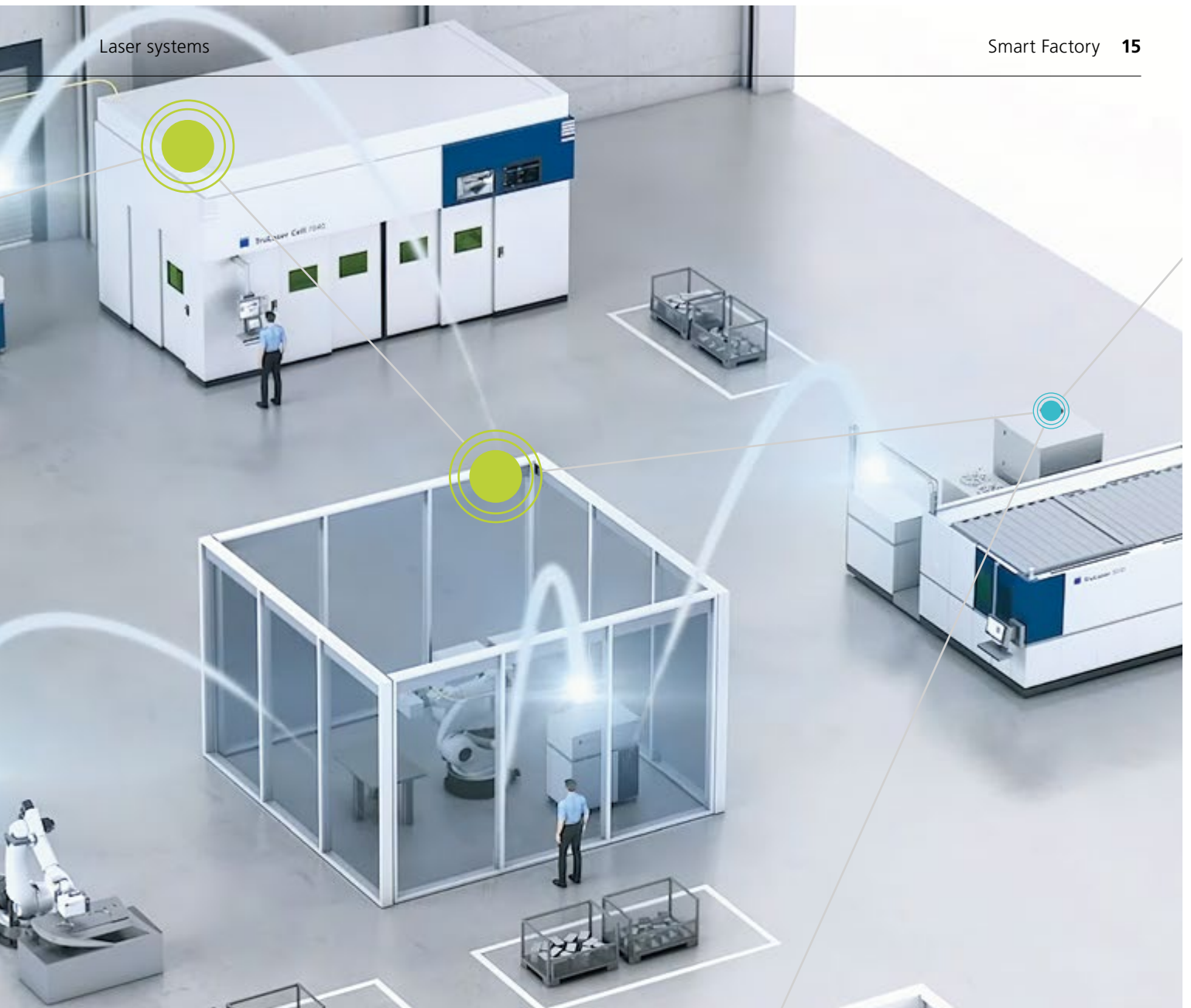

## Production status interface (OPC UA)

The production status interface (OPC UA) offers the opportunity for networking your machinery and preparing applications for Industry 4.0. With the OPC UA communication standard you can use machine data such as control variables, measured values, or parameters for individual applications.



Advantages of networking:

- Increase in productivity
- Increased availability through reduction of idle states
- Transparent overview concerning the statuses of your production
- Traceable process data



Uncover your production's hidden potential:  
[www.trumpf.com/s/d0w8vz](http://www.trumpf.com/s/d0w8vz)

# Easy programming

With TRUMPF software solutions, you can operate and program your laser machines in no time at all – easy to use and, being based on the entire TRUMPF know-how, with reliably good results. This is how you get the best results from your machine.

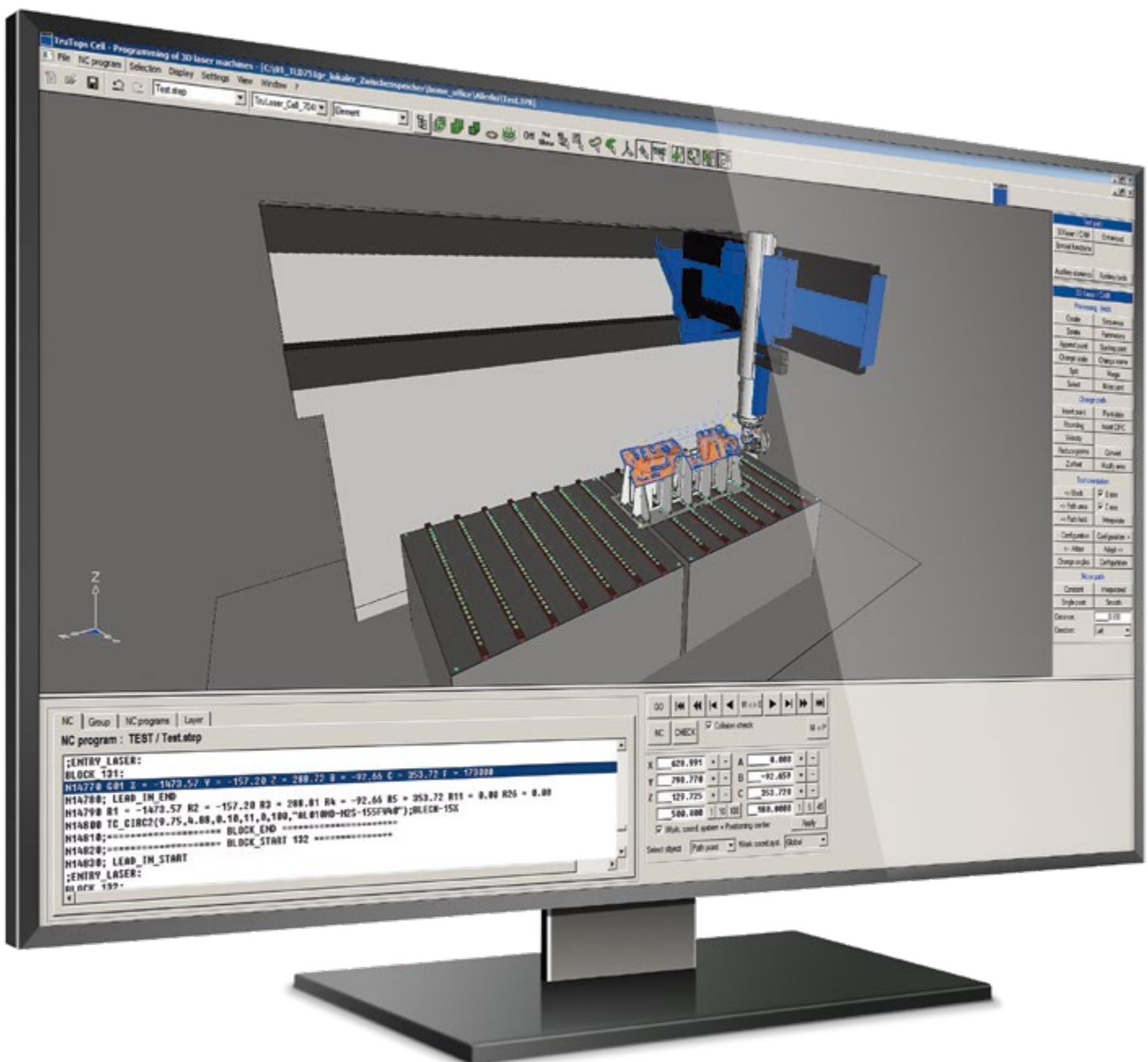

You can find further information here:  
[https://www.trumpf.com/filestorage/TRUMPF\\_Master/Products/Software/Brochures/TRUMPF-Software-EN.pdf](https://www.trumpf.com/filestorage/TRUMPF_Master/Products/Software/Brochures/TRUMPF-Software-EN.pdf)



## TruTops Cell Basic

Check and modify processing programs directly at the machine.

### Optimal process reliability thanks to visual feedback

The program visually simulates the individual programmed processing steps. This way, you can quickly check if you will get the result you want. Every program change is immediately visible.

### Easy optimization of existing programs

Besides the direct programming of the NC program, you can make direct changes with the intuitive graphic user interface of the machine control. This way you save a lot of time in the midst of ongoing operations.

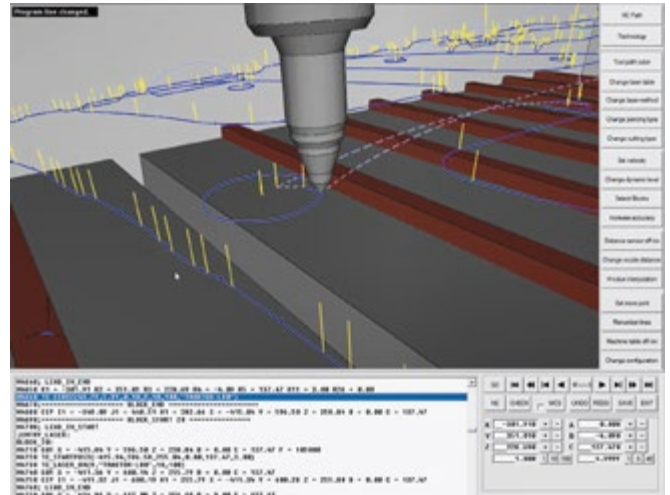

## TruTops Cell for 3D processing

Comprehensive solution for cutting and welding

### Offline programming

The machine continues to run while you are already generating or adapting new NC programs at your computer. The processing program can predict possible collisions, automatically preventing them and optimizing processing trajectories. The modifications you make at the machine control are immediately adopted by TruTops Cell.

### Automatic optimization

With just a few clicks, you can select the most suitable stored technology settings and use them to perfect your machining process. The entire TRUMPF know-how has flowed into the

program, and it automatically prepares for you the right process parameters for your application.

### Integrated fixture module option

With TruTops Cell, you can generate a CAD model of the suitable cutting fixture with just a couple of clicks. Clever additional functions then optimize it further.

### Compatible with all data formats

TruTops Cell can be used with all current data formats. Being equipped for cutting, welding and laser metal deposition, the program also supports all TruLaser Cell machines.

## TruTops Boost for efficient 2D laser cutting

Get even more out of your machine.

### Efficient machine utilization thanks to algorithms

A common pool of orders and the Lean Nest nesting processor provide what you need for optimal material utilization. The software also shows you an overview of the statuses of your orders.

### Automatic part tracking

Equip your production unit for Industry 4.0. With a great number of other optional functions, this program will open up whole new perspectives for modern production control.

### Automatic and interactive operation

The intuitive operation of this software enables you to work with even greater productivity. The choice is yours as to whether you program interactively or leave it up to the automatic functions of the software.



# Intelligent functions

Which intelligent functions are available with which machine series?  
This table gives you a quick overview.



TruLaser Station 7000

TruLaser Cell 3000

Technologies		
Cutting		■
Welding	■	■
Laser metal deposition		■
Functions		
<b>X-Blast</b> Greater machine availability and better edge quality when laser cutting 3D parts because you double the clearance between the nozzle and sheet		
<b>BrightLine Weld</b> Low-spatter, energy-efficient laser welding using the revolutionary BrightLine Weld technology with patented 2-in-1 LLK	■	■
<b>ObserveLine</b> Patented check system for the automatic check of axis precision and automatic check for fallen cut-out waste at an unprecedented speed		■
<b>Dynamic cutting optics</b> Highly dynamic extra axis in the optics for the fastest distance regulation possible and maximum performance		
<b>VisionLine</b> Intelligent process viewing with a digital camera image in the laser focal point and many additional functions	■	■
<b>Smart Optics Setup</b> Test station which can be swiveled into the working area for fast and reliable execution of typical setup tasks		
<b>CalibrationLine Power</b> Automatic inspection of your laser power to ensure constant processing quality	■	■
<b>FocusLine</b> Automatic correction of the focus point while processing		■
<b>FocusLine Professional</b> Optical system for continuous spot diameter and focal diameter variation		■
<b>FastLine Cell</b> Piercing on-the-fly for higher productivity		
<b>Smart Approach</b> Patented system for faster and more reliable approach to the outer edge of the component, for the shortest possible cycle time with outer cuts		
<b>TruTops Cell Basic</b> Graphical user interface on the machine control for the convenient checking and modification of programs, with visual simulation		■



TruLaser Cell 5030



TruLaserCell 7040 CO<sub>2</sub>



TruLaser Cell 7040 fiber



TruLaser Cell 8030

Function Overview				
Function	TruLaser Cell 5030	TruLaserCell 7040 CO <sub>2</sub>	TruLaser Cell 7040 fiber	TruLaser Cell 8030
Basic	■	■	■	■
Automatic	■	■	■	■
Automatic			■	
Automatic				
Advanced Functions				
Automatic	■	■	■	■
Automatic	■		■	■
Automatic	■		■	■
Automatic		■	■	■
Automatic	(■)*		■	■
Automatic	■	■	■	■
Automatic				
Automatic	■	■	■	■
Automatic				
Automatic		■	■	■
Automatic		■	■	■
Automatic	■	■	■	■

\* Basic.

# TruLaser Cell 1100

The specialist in the laser welding of tubes, profiles and straps

01

## Easy to integrate

thanks to a flexible, compact structure

02

## Extremely efficient

thanks to state-of-the-art beam sources and calibrated sensors

03

## Perfectly accessible

through variable adjustable axes

04

## Fully customized

Optional extras offer solutions for every application



01

## Easy to integrate

thanks to a flexible, compact structure

Make life easy for yourself: The compact and modular TruLaser Cell 1100 can be integrated into your production lines with the utmost ease. You can configure the beam guidance system to meet your specific needs in terms of the linear axes, the working height or process path. This makes it possible to weld in two different places at the same time.



Non-stop manufacture – the system for endless welding professionals.

02

## Extremely efficient

thanks to state-of-the-art beam sources and calibrated sensors

With the TruLaser Cell 1100, you can step your production process up a gear. Simply choose the right beam source for your application – CO<sub>2</sub> laser or solid-state laser – and the system is highly flexible when it comes to positioning the beam and optics. The perfectly calibrated sensors guarantee optimum welding results. All of these factors together cut your operating costs and increase your production speed.

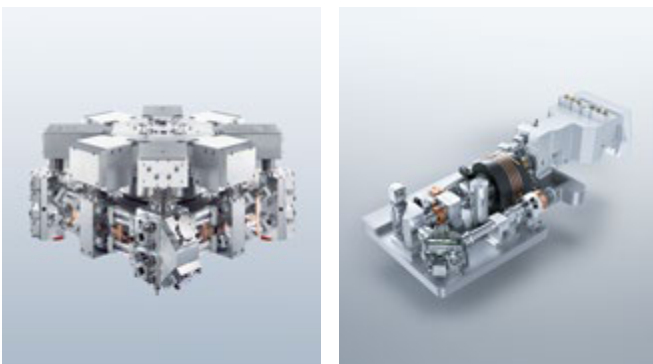

Use the beam source you need: The TruFlow CO<sub>2</sub> laser (left) or the TruDisk disk laser – the choice is yours.

03

## Perfectly accessible

through variable adjustable axes

The variable setting axes offer ideal adjustment options, for both tubes and profiles. Thanks to its compact design, the variable beam guidance can be integrated into all current profile systems. The sophisticated beam forming feature enables top welding quality at maximum feed even with high requirements and the most diverse of seam geometries.



Equipped with the most modern process technology for demanding tasks.

04

## Fully customized

Optional extras offer solutions for every application

Be more flexible thanks to a wide range of welding optics with linear or swivel axes. Sensor systems for finding and tracking seams together with functions such as SeamLine and SeamLine Pro guarantee maximum quality, reliability and productivity.

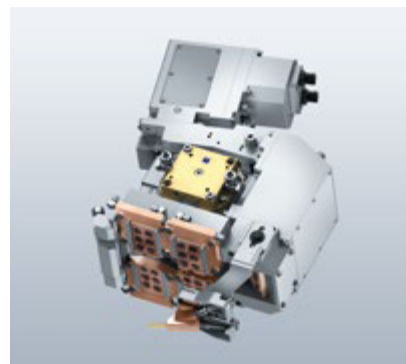

You too can achieve the perfect seam with the right process monitoring system.



You can find still more information about the TruLaser Cell 1100 here: [www.trumpf.com/s/20q1n3](http://www.trumpf.com/s/20q1n3)

# TruLaser Cell 3000

The universal machine for the 2D and 3D laser welding, laser cutting and laser metal deposition of small to medium parts

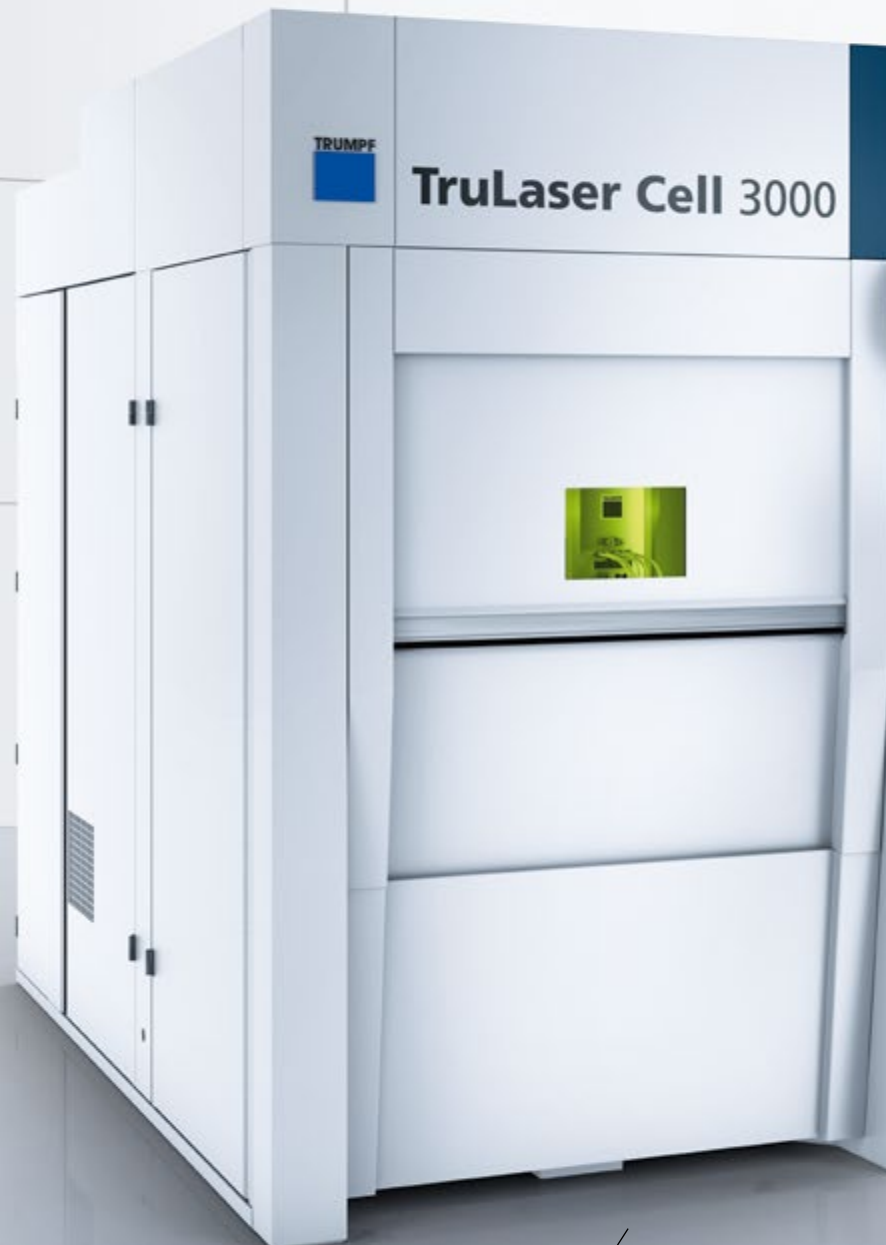

01

## Unique process flexibility

Welding, cutting, laser metal deposition

02

## Highly productive processing

due to customized automation solutions and a dynamic axis system



05

## Spacious and most flexible work area

with compact machine design

04

## Reliable processing

due to intelligent image processing and laser power sensor system

03

## Cost-efficient production

with top component quality



You can find anything else you would like to know about the TruLaser Cell 3000 here: [www.trumpf.com/s/woxy9](http://www.trumpf.com/s/woxy9)

01

## Unique process flexibility

Welding, cutting, laser metal deposition

Trend-setting flexibility without compromise. Having a broad variety of functions available, the machine can be equipped for every application. With the flexible optical interface, even scanner optics of the PFO series can be attached, for example, to weld e-mobility components. An interpolating rotation-swivel axis offers optimal 3D accessibility for laser metal deposition.

### Welding



### Cutting

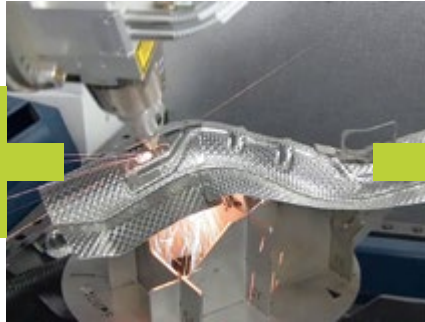

### Deposition welding



02

## Highly productive processing

due to customized automation solutions and a dynamic axis system

High quantities? No problem. Using a rotary table for loading and unloading parallel to production, and a highly dynamic axis system with a linear drive, you will cut down your production times considerably. The automatic lateral lifting doors enable the system to be connected to a transfer system and loaded by robots. The ability to automate the TruLaser Cell 3000 makes it easy to integrate into complete production lines.



The TruLaser Cell 3000 can be automated very easily, for example from the front with robots, or laterally with a coil connection or to a flow line.



03

## Cost-efficient production

with top component quality

When it comes to laser welding, BrightLine Weld sets new standards with regard to the welding speed and quality. Depending on the material concerned, it enables an increase in the feed rate of up to 300% or a reduction in energy consumption of up to 40% whilst ensuring the same welding depth. In combination with the highly precise axis system, this ensures the very best component quality at all times.

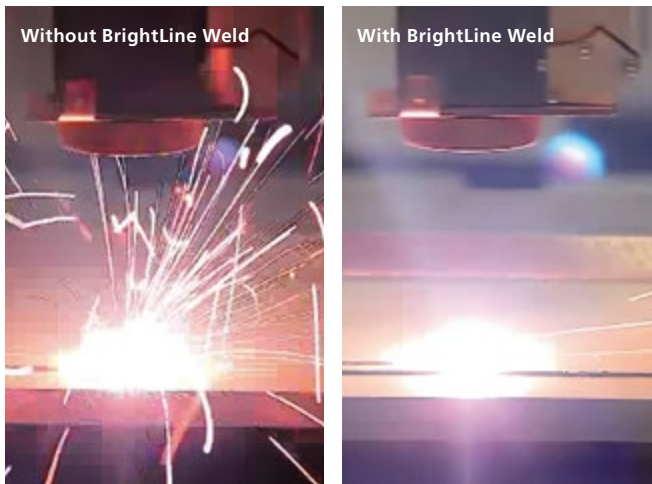

With BrightLine Weld, materials such as mild steel, stainless steel, or even copper and aluminum can be welded virtually spatter-free.

05

## Spacious and most flexible work area

with compact machine design

More for your money: Boasting the largest and most flexible work area in its class, the TruLaser Cell 3000 not only offers space for large installations and comprehensive fixtures and automation systems. With an additional motor-driven workpiece axis, you can also process 3D components which are up to 50% larger.

04

## Reliable processing

due to intelligent image processing and laser power sensor system

Powerful sensor systems ensure comprehensive process monitoring and fault-free machining processes. VisionLine image processing automatically detects the position of the component, forwards the information to the controls, and ensures that the weld seam is always positioned in the right place. CalibrationLine guarantees a constant laser power on the workpiece.

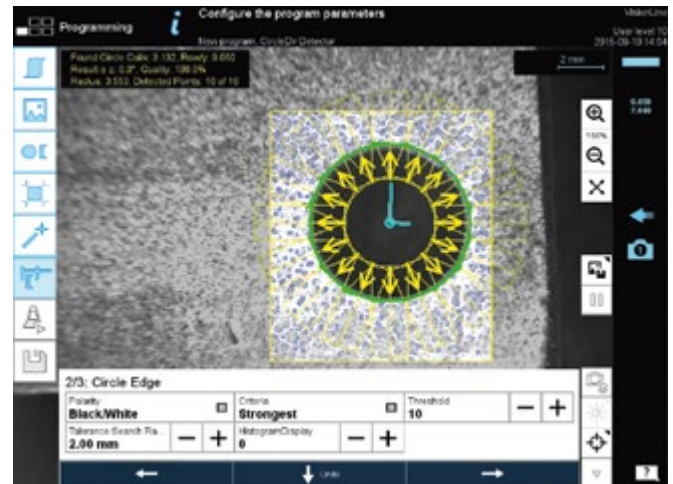

The image processing automatically measures the component, ensures safe and reliable processes during welding, and prevents the production of faulty parts.

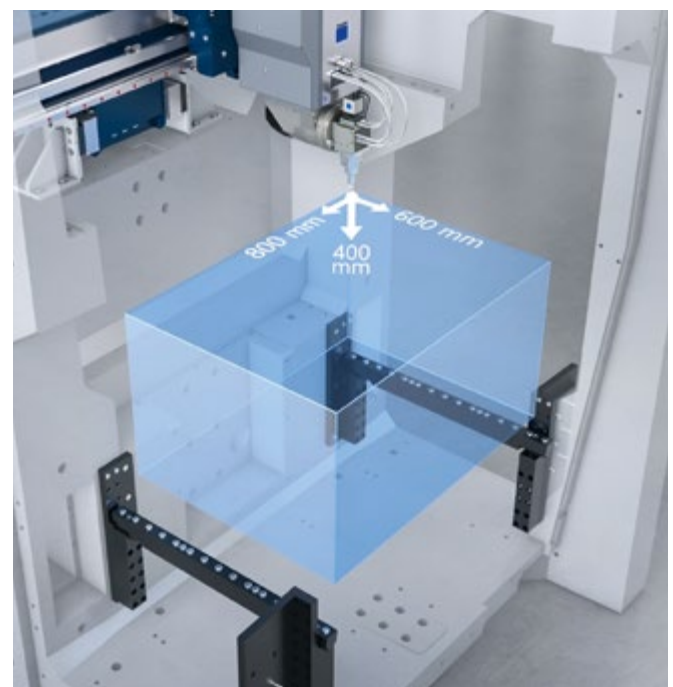

The large work area can also be accessed from the side and enables large components to be processed in a minimal installation area.

# TruLaser Cell 5030

The entry model for 2D as well as 3D laser cutting and welding of large parts



01

## Low-cost introduction

to 3D laser cutting and welding

02

## Top operator convenience

due to intuitive software support



03

**Dynamic and precise**  
with flying optics

04

**Top quality**  
due to unique features

05

**Process flexibility for cutting and welding**  
with 2-in-1 LLK



More information about the TruLaser Cell 5030 can be found here:  
[www.trumpf.com/s/j5ra70](http://www.trumpf.com/s/j5ra70)

01

## Low-cost introduction

to 3D laser cutting and welding

Cost-efficient processing starting with the very first part: Compared to hybrid and sheet mover machines with CO<sub>2</sub> lasers, the TruLaser Cell 5030 achieves up to 300% higher performance with a machine-hour rate reduction of up to 20%. Its clever design reduces the installation area of the system to a minimum.



The system impresses with low maintenance costs.

02

## Top operator convenience

due to intuitive software support

The TruLaser Cell 5030 is optimal for the processing of frequently changing orders with small lot sizes. The running-in of new parts is supported by clever features like, for example, the stored technology parameters for all currently used materials, the TruTops Cell Basic program for quick program modifications or the automatic focus setting. The front doors of the machine are made of light CFRP material, enabling quick and convenient access to the work area.



The teachbox allows you to operate your machines easily and with flexibility.

03

## Dynamic and precise

with flying optics

With X-Blast Technology you work at a greater distance to the sheet metal. This reduces nozzle collisions and increases the quality of the 3D cutting edges. Flying optics also contribute to precise results. Nevertheless, in the event of a collision, the magnetic coupling prevents damage to the machine.

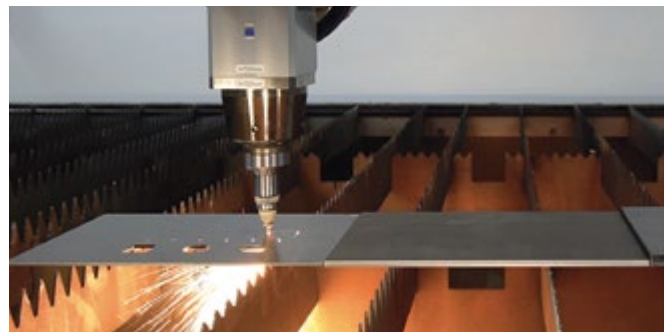

Extremely high processing speeds are enabled by the same optical setup and drive principle as in 3D high-end machines.

04

## Top quality

due to unique features

Optimal coordination between laser, machine, and software forms the foundation for excellent processing quality. With the TruLaser Cell 5030 you have all three building blocks from TRUMPF. Machine operators are supported by the latest functions such as Smart Optics Setup, for a quick and convenient setup. The precision of the machine can be automatically tested during the production process with ObserveLine Professional. This reduces the production of faulty parts to a minimum. The BrightLine Weld option enables laser welding almost free of spatter and optimal weld seam quality. At the same time, significantly higher feed rates can be achieved with this option, and energy costs can be reduced.



You can weld materials such as mild steel, stainless steel or even copper and aluminum almost free of spatter using BrightLine Weld.

05

## Process flexibility for cutting and welding

with 2-in-1 LLK

The 2-in-1 LLK solution for solid-state lasers enables the use of the same optical cable for both welding and cutting operations. When switching between the two methods, only the processing optics has to be changed, the system control then adjusts the laser beam automatically. And you will also be impressed by the easy operation and top processing results. The standard work table used in all applications is also available as a moveable table. Special 3D work tables are also available as an alternative.

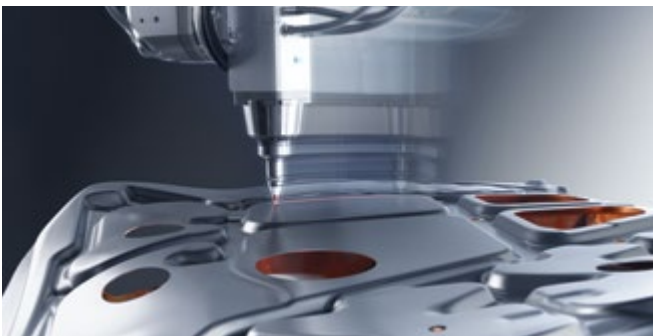

The same optical setup and working principle used with the high-end 3D machines make top processing speeds possible.



The manually adjustable focus position enables you to perform both deep penetration and heat conduction welding with the same processing optics.

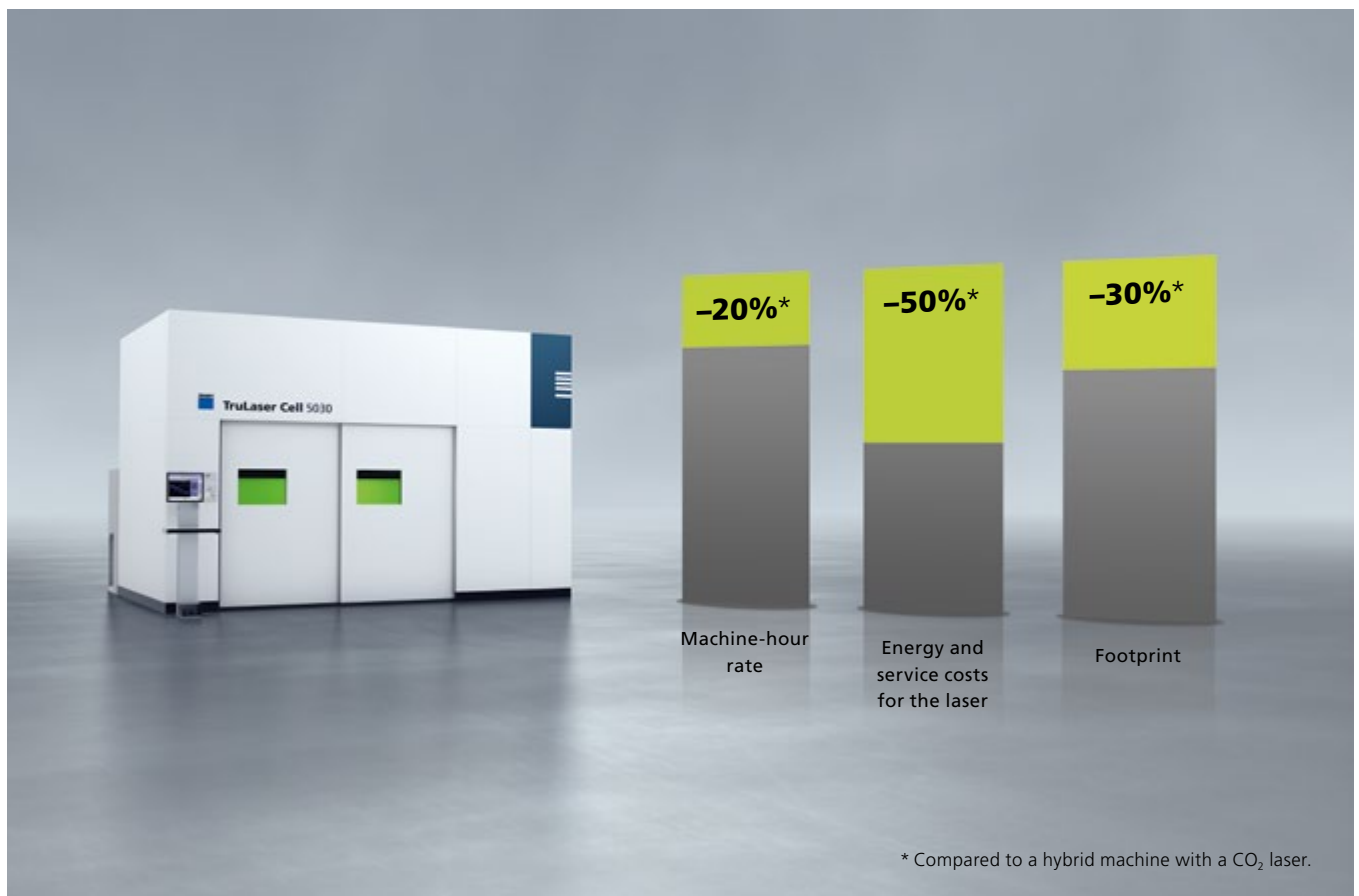

300% higher productivity, efficient solid-state laser and compact design – the TruLaser Cell 5030 offers great benefits compared to hybrid machines with a CO<sub>2</sub> laser.

# TruLaser Cell 7040

The perfectionist when it comes to 2D and 3D laser cutting and laser welding as well as laser metal deposition of large parts



01

## Unique flexibility

in 3D processing with solid-state or CO<sub>2</sub> lasers

02

## Top productivity

with frequently changing series and lot sizes

03

## Top process reliability and quality

thanks to X-Blast Technology, low-spatter welding and intelligent image processing

04

## Perfectly ergonomic

with the movable control panel and evenly illuminated work area

05

## Quick part setup

using teach panel, MobileControl App and TruTops Cell Basic



More information about the TruLaser Cell 7040 can be found here:  
[www.trumpf.com/s/weoethn](http://www.trumpf.com/s/weoethn)

01

## Unique flexibility

in 3D processing with solid-state or CO<sub>2</sub> lasers

The TruLaser Cell 7040 was specially developed for a flexible production environment. You can switch between 3D cutting and welding as well as laser metal deposition. The 2-in-1 LLK also automatically adjusts the laser beam optimally to suit the respective processing task. This means you are always perfectly equipped.



With the additional axis integrated in the optics, you can get perfect cutting results with high cutting speeds, even with complex 3D geometries. The X-Blast Technology makes the process extremely robust.



Perfect cutting results and high seam quality thanks to the almost spatter-free processing with BrightLine Weld, even at high processing speeds.

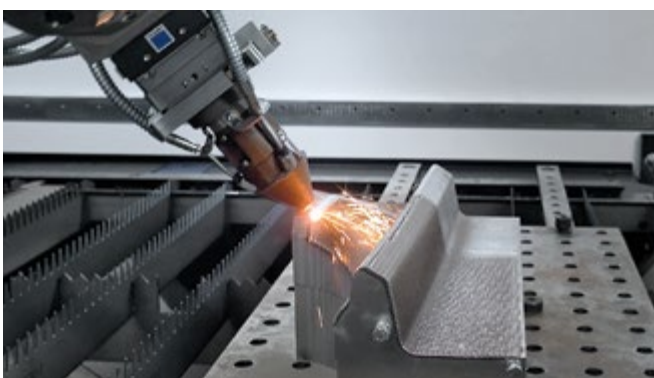

With laser metal deposition, three-dimensional parts can be coated, repaired or have their shape modified.

02

## Top productivity

with frequently changing series and lot sizes

High positioning speeds and axis dynamics allow for low production times. On-the-fly piercing with FastLine Cell reduces your nonproductive times by up to 40% when cutting. The front doors made of light GFRP material cut your time opening and closing doors by 35%. And you save even more time with loading and unloading parallel to production in 2-station operation and with an extremely fast rotary table which revolves the part into the work area in only 4 s. You manufacture more profitably than ever before, and that with absolute reliability.



You can load and unload parallel to production with the quick-turning rotary table. User-friendly component handling outside the machine is also possible. This saves money and time.

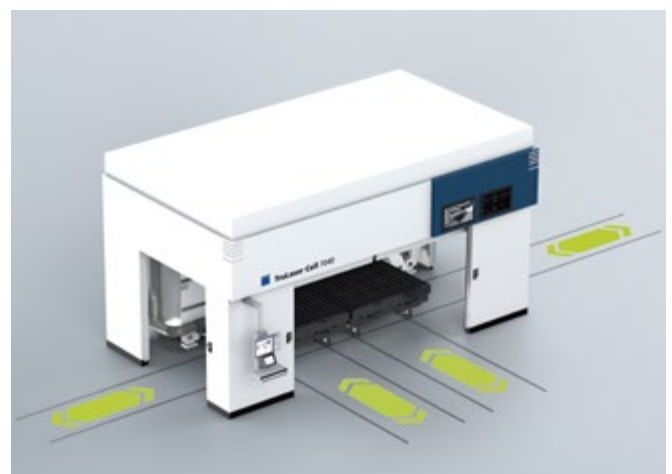

Quick setup with heavy components using tables which are movable in the X and Y directions.



03

## Top process reliability and quality

thanks to X-Blast Technology, low-spatter welding and intelligent image processing

The X-Blast nozzle technology ensures consistently good 3D cutting quality due to the greater nozzle-sheet distance. The ObserveLine sensor system inspects the cut contour at lightning speed. With the low-spatter welding provided by BrightLine Weld, outstanding weld seam quality and at the same time a tripling of the feed rate is achieved. Using the image processing feature VisionLine, you are always sure that the weld seam is placed at the right position. This noticeably increases the quality of your components, and saves time and money.

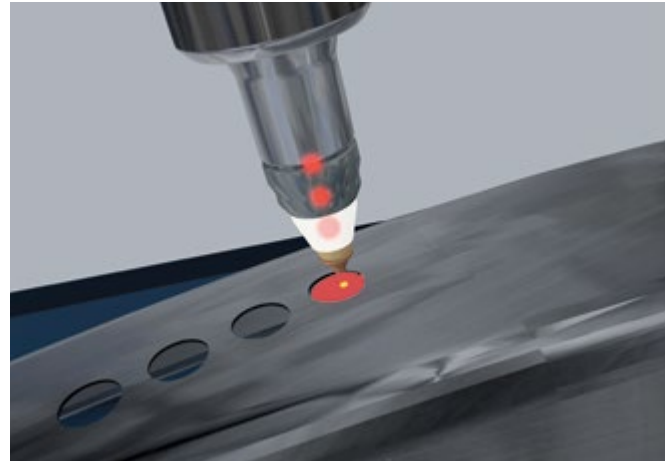

Patented ObserveLine testing system for automated inspection of cut contours.

04

## Perfectly ergonomic

with the movable control panel and evenly illuminated work area

The ergonomic control panel can be moved along the entire machine, ensuring a perfect view of the work area from every angle. The bright and optimally illuminated work area guarantees constant comfort while working. The Smart Optics Setup station also ensures that setting the optics is quick and reliable.



Smart Optics Setup ensures quick and reliable setting and adjustment work on the optics.

05

## Quick part setup

using teach panel, MobileControl App and TruTops Cell Basic

The compact teach panel with 6D mouse makes it easier to run in, teach and traverse the axes. With the TruTops Cell Basic software, the programs can be adapted directly at the machine – without making changes to the offline programming system. In addition, the control automatically detects which optics are installed, allowing for a quick and error-proof change of optics.



Quick program creation directly at the workpiece with the MobileControl App and teach panel.

# TruLaser Cell 8030

The expert in the 3D laser cutting of hot-formed parts



01

## Top productivity

in series production

02

## More efficient production

thanks to the economical TruDisk 2000

03

## Clever functions

for high processing dynamics and safety

04

## Save space

due to the compact installation area



05

## Large components

processed efficiently

06

## Stable cutting process

with the X-Blast nozzle



You can find out even more about the TruLaser Cell 8030 here:  
[www.trumpf.com/s/uv1ld5](http://www.trumpf.com/s/uv1ld5)

01

### Top productivity

in series production

You process at maximum productivity with the TruLaser Cell 8030. Part times are reduced up to 7% using dynamic level 3. The numerous functions like, for example, the optimized rotary table, provide process reliability and shortened nonproductive times. The 20% reduced rotation time of 1.8 s is the fastest on the market. Intelligent automation solutions ensure that there are no bottlenecks, even with manual loading and unloading. You can optimize cycle times and achieve greater productivity using a rotary indexing table or a robot for part automation. With ObserveLine Comfort, the improved slug check is 4 times as fast as the competition.



A rotary indexing table and robots keep cycle times to a minimum.



The remaining time display lets you know at a glance how the component, and indeed the entire order, is progressing.

03

### Clever functions

for high processing dynamics and safety

Two optical measuring processes ensure greater reliability on the TruLaser Cell 8030: ObserveLine Comfort checks with lightning speed whether a contour has been fully cut out, thereby preventing cutting the cut-out scrap from remaining in the finished part. ObserveLine Professional monitors the positioning accuracy of the machine and can detect even the tiniest of positioning errors of the optics. The precise and secure magnetic coupling enables you to carry on working in no time at all, even in the event of a collision. With assistants like these, you save money by producing faster and reducing rejects.



The ObserveLine Comfort measuring system ensures that every cutout is indeed cut out and gone.



The ObserveLine Professional measuring system monitors the correct positioning of the optics.

02

### More efficient production

thanks to the economical TruDisk 2000

The choice is yours: No matter what your application, you have a wide range of lasers at your disposal. Using the TruLaser Cell 8030 with a compact fiber-guided TruDisk 2000 laser, for example, would make your production process especially efficient. This system boasts unsurpassed beam quality and exceptional focusability, which saves electricity and thereby reduces the cost per part – and even has a positive effect on the size of your investment.

#### Energy consumption

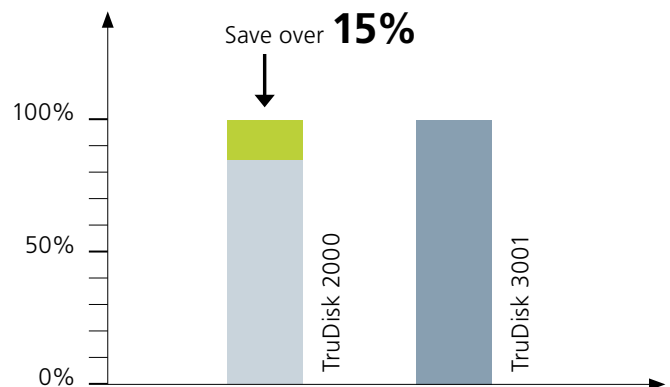

You also save on power input with TRUMPF solid-state lasers.

04

## Save space

due to the compact installation area

Lacking space in your production facility? No problem! The compact TruLaser Cell 8030 has a very small footprint, meaning you have the flexibility to plan multiple machines into your workspace according to your specific needs. A further advantage of the system is that it is ergonomic and extremely easy to use. The rotating changer can be loaded and unloaded from the front as well as the sides.



The compact, easy-to-use laser cell fits into any production line.

05

## Large components

processed efficiently

Produce large parts with top productivity. The working area of the TruLaser Cell 8030 can be extended as desired. With this concept, you can process door rings or other large hot-formed parts efficiently and completely.



You can even process very large hot-formed parts with the TruLaser Cell 8030.

06

## Stable cutting process

with the X-Blast nozzle

The optimized cutting nozzle processes at a greater clearance from the sheet – this reduces downtimes caused by nozzle collisions by 90%. Profit not just from the greater machine availability, but also from a 10% drop in nozzle wear and from optimal cutting edges, especially when tackling highly demanding 3D geometries.

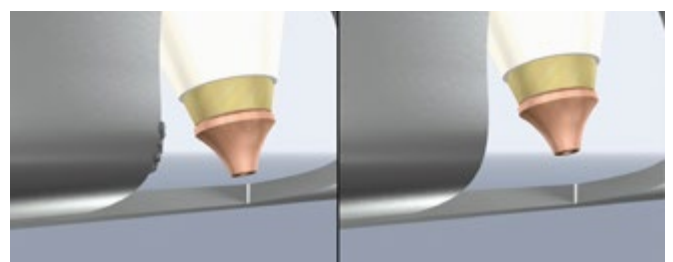
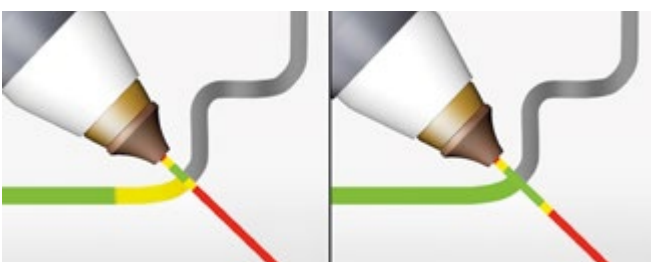

Even small radii can be cut with great quality with X-Blast thanks to a doubled processing spectrum.

# TruLaser Station 7000

The compact solution for the 3D laser welding  
of small parts



01

## Spacious work area on a minimized footprint

offering room even for larger components

02

## Profitable laser welding

thanks to the best price-  
performance ratio of its class

03

## Constant high part quality

with fully integrated  
image processing



06

## Optimal for complex welding geometries

thanks to its highly developed 3D processing technology

05

## High processing flexibility

guarantees a variety of welding applications

04

## Ideal for large quantities

because of the rotary table



You can find more information about the TruLaser Station 7000 here:  
[www.trumpf.com/s/trulaser-station-7000](http://www.trumpf.com/s/trulaser-station-7000)

01

## Spacious work area on a minimized footprint

offering room even for larger components

The TruLaser Station 7000 offers the perfect balance between work area and footprint. A broad spectrum of parts can be processed in the generously designed work area of the machine – including larger parts and even complex fixtures. The exhaust system is integrated in the machine.



The machine design has been optimized to provide the maximum work area despite its minimized footprint.

02

## Profitable laser welding

thanks to the best price-performance ratio of its class

The modular design of the TruLaser Station 7000 will keep your investment costs down. This modern machine concept is perfectly designed for welding assemblies such as sensor systems, rotationally symmetrical parts and medical instruments. You will also be impressed by the low cost per part.



Welding seams on a power sensor module.

03

## Constant high part quality

with fully integrated image processing

The integrated image processing feature detects component geometries. This means that you always weld at the right point and save time and money as you produce with unchanging high quality. The intuitive user interface takes the operator quickly through the individual work steps on the spacious touchscreen.



The height and angle of the ergonomic operating panel can be freely adjusted to the operator's preference. It can be positioned left or right of the machine.



04

## Ideal for large quantities

because of the rotary table

The TruLaser Station 7000 can be optimally equipped with a rotary table. This enables loading and unloading parallel to production, even when automated with a robot. High-power lasers of the latest generation enable optimal processing times, making the machine perfectly suited for highly productive series production.



The 2 stations of the rotary table make loading possible even when the machine is operating. With this, you maximize your productivity.

05

## High processing flexibility

guarantees a variety of welding applications

Weld very diverse seam geometries at a constantly high level of quality. No matter whether you are using heat conduction or deep penetration welding, whether it's with thin or thick sheet – the TruLaser Station 7000 offers high performance. You can choose between swiveling welding optics and scanner optics and select among a wide variety of beam sources.



Whether you want to weld electrical contacts for control units, medical instruments or ultrasonic sensors – the TruLaser Station 7000 can be adapted to your requirements.

06

## Optimal for complex welding geometries

thanks to its highly developed 3D processing technology

With up to 5 interpolating axes you can handle complex 3D components and seam geometries without any problem. The corresponding fixture equipment can be accommodated in the spacious working area and can be programmed using a traveling operator interface.



3D laser welding in the medical technology field.

# TruMark Stations

Turnkey laser marking solutions



**TruMark  
Station 3000**

**TruMark  
Station 5000**

**TruMark  
Station 3000  
Desktop**

- Components in a range of sizes and weights
- Desktop and stand-alone units
- High level of productivity and automation
- Simple operation
- Infrared, green and UV lasers available
- Can be expanded with options including image processing, rotary axes and other handling systems



[www.trumpf.com/s/productfinder-1](http://www.trumpf.com/s/productfinder-1)



**TruMark  
Station 7000**

**TruMark  
Station 7000R**



Further information  
on the marking systems  
can be found here:  
[www.trumpf.com/s/marketing-systems](http://www.trumpf.com/s/marketing-systems)

# TruMark Station 7000 and 7000R

## Marking of large and heavy components

The TruMark Station 7000 marking system offers plenty of space for your workpieces and devices with its large interior dimensions. It is possible to mark both individual large as well as heavy components, or a large number of smaller parts alongside each other and process them automatically.



## Perfect marking results thanks to a large range of lasers

Lasers with different power classes, wavelengths and pulse durations are available for the TruMark Station 7000. Furthermore, additional options such as a rotary table, focusing lenses, camera systems, and lighting provide additional flexibility. For example, rotationally symmetrical workpieces can be fully processed using swivel mechanisms and rotary axes.



## Batch production specialist

The TruMark Station 7000 can be easily integrated into efficient batch production. Automatic loading and unloading and a connection to a storage system provide an additional boost in productivity. The station is ideal for handling large lot sizes – especially the variation with the rotary table option. The components are brought to the machining area and processed using a rotary plate. The machine can already be reloaded with components during the machining process.



# TruMark Station 5000

---

## Universal solution

---

A number of lasers with different focusing lenses, focal lengths and wavelengths are available for the TruMark Station 5000.



---

## Ready to use anywhere – in your flow line or as a stand-alone workstation

---

Benefit from our unbeatable combination of a larger working range plus a compact design. The TruMark Station 5000 is ideally suited for use in your flow line. Or set it up as a stand-alone workstation. Standing up or sitting down? Thanks to the intelligent ergonomic design, it is up to you!

---

## Flexible integration

---

The TruMark Station 5000 makes life easy for you: You can easily integrate it into your flow line thanks to the housing's side openings for the flow-through transfer of workpieces. Or why not opt for the TruMark Station 5000 without any housing (laser class 4) for processing larger components? You also have the option to expand the sealed work area on both sides.



# TruMark Station 3000 desktop and stand-alone unit

## Perfectly equipped

The TruMark Station 3000 is perfectly suited to customers with small and medium lot sizes. An optional rotary axis increases the marking station's flexibility. And if you want to switch to batch production, simply remove the side flaps and feed your production line through.



TruMark Station 3000 stand-alone unit.

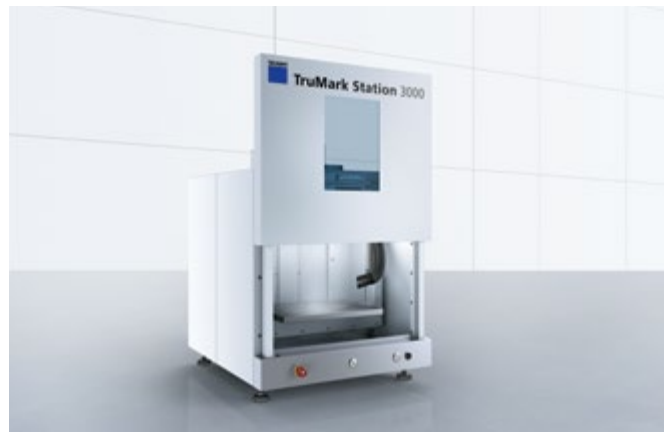

TruMark Station 3000 desktop.

## Compact desktop application

Equipped with a TruMark one-Box laser, the TruMark Station 3000 will even fit onto your desk thanks to its compact outside dimensions. There is also a stand-alone version available for standing and sitting operation in the processing area.

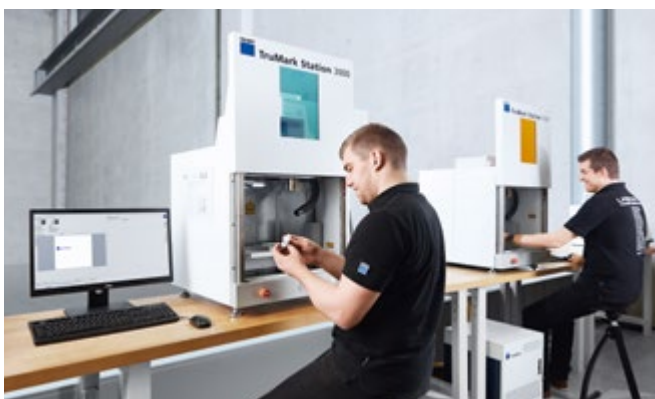

## A comfortable way to work

The TruMark Station 3000's operating elements feature an ergonomic layout, and the system is controlled using the tried-and-tested TruTops Mark marking software. An automatic door ensures quick and convenient loading and unloading. A motorized Z axis also supports the positioning of the components and the setting of the exact focus position.



# VisionLine image processing

## Always in focus

Save time and money and still get maximum marking quality

The distance measurement function<sup>[1]</sup> provides support when setting the working distance. The objective of the on-axis camera can be focused on any position in the marking area on which the laser is concentrating. Focusing of the processing beam and the camera are independent of each other.



<sup>[1]</sup> Distance measurement function in the center of the marking field. Automatic distance correction only in combination with the TruMark Station 5000 or 7000.

## Modular setup

Optimal adjustment for every application situation

Assemble the right package from the VisionLine product series – consisting of Adjust, Detect, Model, Code and OCR – that is tailor-made to the requirements of your actual application. The hardware is always included: One camera is aimed through the scanner lens (on-axis), a second one is laterally aimed at the marking field (off-axis). The on-axis camera can find the correct marking position on the component. Thanks to the stitching function – which strings images together – you can even keep an eye on large components. The off-axis camera reduces the process time, as the entire marking field is captured in one camera image, making stitching unnecessary. There is also the option of selecting lighting – in the wavelength suitable for the respective marking laser.



You can find further information here:  
[www.trumpf.com/s/image-processing](http://www.trumpf.com/s/image-processing)

# TruTops Mark 3D

## Intuitive handling

Full-featured 3D CAD software

2D and 3D marking with TRUMPF marking lasers has never been so quick and easy: Our TruTops Mark 3D marking software features impressive user-friendly operation and significantly shorter processing times. Depending on the application, it is now possible to mark multiple objects with a single laser system – where in the past several lasers would have been required. This saves you money while increasing flexibility. The newly developed wrap algorithms from TRUMPF guarantee that the marking is undistorted and aesthetically pleasing.

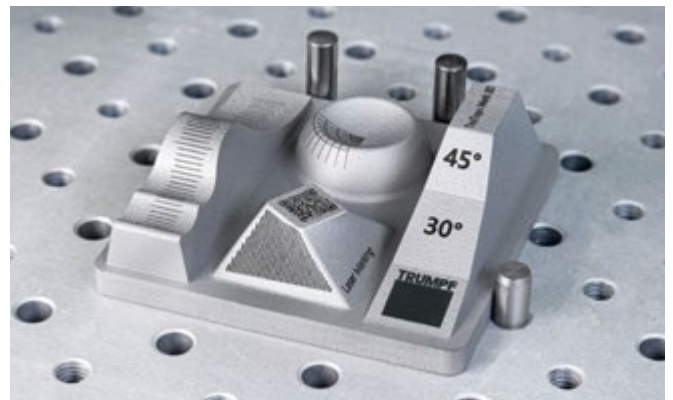

You can find further information here:  
[www.trumpf.com/s/trutopsmark-3D](http://www.trumpf.com/s/trutopsmark-3D)

# The right solution for every metal AM application

From prototype manufacturing to industrial serial production



## Our additive production systems for metal powder

As a pioneer in additive technologies and a specialist in lasers, we offer the perfect technology for any application requirement: be it laser metal fusion (LMF/LPBF) or laser metal deposition (LMD). Benefit from industrial solutions with intelligent monitoring and smart services around the world. Still on the lookout for an application that you'd like to produce using additive manufacturing? Speak to our consultants for newcomers to the world of AM.





**Sounds interesting? Then visit our  
AM showroom – either in person or virtually.**

[www.trumpf.info/am-showroom](http://www.trumpf.info/am-showroom)



Find out more about our extensive additive manufacturing product portfolio at: [www.trumpf.com/s/additivemanufacturing](http://www.trumpf.com/s/additivemanufacturing)

# TruServices. Your Partner in Performance

For a successful future, rely on services which will carry you forward in the long term, and use them to create the best conditions for the success of your production. We create opportunities together, so that you can use your TRUMPF laser systems optimally at all times and adjust to changes with flexibility. In us you will find a reliable partner who supports you with tailor-made solutions and service packages – so that you can produce economically and at a consistently high level, thus optimizing your value creation sustainably.

## **EMPOWER**

If you wish to create the best conditions for successful manufacturing: We will support you in this.

## **SUPPORT**

If flexibility and availability of equipment in day-to-day operations are essential to you: We are there for you.

## **IMPROVE**

If you want to gradually focus your manufacturing on maximum value creation: We will work together to reach your goal.

Service Agreements



Select the right scope of services for you with predictable costs – technical hotline, remote support, on-schedule maintenance, repairs including spare parts. You benefit from inexpensive package prices and lower processing outlay.

Technical Service



Our global service network helps you with quick, technical support, and preventively ensures the availability of your TRUMPF system. We support you from installation to maintenance all the way to system repairs. Customer service specialists advise you on which solution is the most efficient in your case – in-person support on-site or problem-solving via remote support.

Process Optimization



With our help you'll be well on your way to finding your production's hidden potential. For example, analyzing the design of your parts, your subprocesses, or your entire production. The results give us the data we need to help you develop selective or holistic solutions, for example for networked production.

Genuine Parts



Produce with as much reliability and precision as possible – genuine TRUMPF spare parts and consumables are ideally suited for your system, and meet top quality requirements. Our global logistics network ensures that you receive the required parts as quickly as possible.



Find out about our comprehensive complete package of helpful services here:  
[www.trumpf.com/s/services](http://www.trumpf.com/s/services)

# Technical Data

## TruLaser Station 7000 TruLaser Cell 3000, 5030, 7040, 8030

Technical Data						
		TruLaser Station 7000	TruLaser Cell 3000	TruLaser Cell 5030	TruLaser Cell 7040	TruLaser Cell 8030
<b>Axis travel range</b>						
X	mm	650	800	3000 (+ 300)	4000	3000
Y	mm	350	600	1500	1500/2000	1300/2100 <sup>[6]</sup>
Z	mm	500	400 (+300) <sup>[1]</sup>	700	750/1000	600/650 <sup>[6]</sup>
B/C <sup>[2]</sup>	°	± 120/n × 360	± 135/n × 360	± 135/n × 360	± 135/n × 360	± 135/n × 360
Max. load capacity	kg	50	400	250 (3Dwork table), 800 (2D/3Dwork table)	1600	300 (700 <sup>[6]</sup> )
<b>Speed</b>						
X/Y/Z	m/min	6	50	60	100	100
Simultaneous	m/min	10	85	104	173	173
B/C <sup>[3]</sup>	1/min	15/200	120/400	60	90/90	90/90
<b>Acceleration</b>						
X/Y/Z	m/s	1	10	5	9/10/10	11 (10 <sup>[6]</sup> )
B/C <sup>[3]</sup>	rad/s	63/157	125/500	200/100	200/100	200/100
<b>Positioning accuracy</b>						
Linear axes X/Y/Z	mm	0.08	0.015	0.08	0.08	0.08
Rotary axes B/C <sup>[3]</sup>	°	0.2	0.02/0.02	0.015	0.015	0.015
<b>Repeatability</b>						
Linear axes X/Y/Z	mm	0.03	0.02	0.03	0.03	0.03
Rotary axes B/C <sup>[3]</sup>	°	0.06	0.006/0.02	0.005	0.005	0.005
<b>Laser</b>						
Max. laser power	W	2000 <sup>[4]</sup>	8000 <sup>[4]</sup>	4000	6000	4000
Available lasers		TruDisk, TruPulse, TruDiode, TruFiber, TruMicro <sup>[2]</sup>	TruDisk, TruDiode, TruFiber	TruDisk	TruFlow, TruDisk	TruDisk
Available technologies		Laser welding	Laser welding, laser cutting, laser metal deposition	Laser welding, laser cutting	Laser welding, laser cutting, laser metal deposition	Laser cutting
<b>Rotary table</b>						
Diameter	mm	770	1070		4600 (5400 <sup>[6]</sup> )	4000 (5000 <sup>[6]</sup> )
Max. load capacity per side	kg	35	95		750/1000	300 (700 <sup>[6]</sup> )
Stations	Number	2	2		2	2
Rotation time	s	On request	3		3	1.8 (3.0 <sup>[6]</sup> )
Total typical non-productive time	s	On request	5.2		6	4.3 (5.5 <sup>[6]</sup> )

<sup>[1]</sup>With additional W1 axis. <sup>[2]</sup>Fiber-guided. <sup>[3]</sup>Rotary axis C180. <sup>[4]</sup>Higher laser power available on request.

<sup>[5]</sup>Dimensions are listed in the standard layout of the customer-specific system. <sup>[6]</sup>Applies for the large version  
Content subject to change without notice. Only specifications in our offer and order confirmation are binding.

## Find out more at [www.trumpf.com](http://www.trumpf.com)

- Technical data sheets available to download
- Clear comparison of up to three products
- Display configured to suit all devices

### TruLaser Cell 1100

Technical Data		
		<b>TruLaser Cell 1100</b>
<b>Axis travel range</b>		
X	mm	300 × 500
Z	mm	300 × 500
Q	mm	± 25
X/Z positioning accuracy	mm	± 0.1
Q positioning accuracy	mm	± 0.05
Max. laser power	W	15000
Available lasers		TruFlow, TruDisk, TruDiode

Content subject to change without notice. Only specifications in our offer and order confirmation are binding.

### TruMark Station 5000, 3000 desktop and stand-alone unit, 7000 and 7000R

Technical Data					
		<b>TruMark Station 3000</b>	<b>TruMark Station 5000</b>	<b>TruMark Station 7000</b>	<b>TruMark Station 7000R</b>
<b>Available marking lasers</b>		TruMark Series 1000, 3000, 5000, 6030	TruMark Series 1000, 3000, 5000, 6030	TruMark Series 3000, 5000 <sup>[1]</sup> , 6030, TruMicro Mark Series 2000	TruMark Series 3000, 5000 <sup>[1]</sup> , 6030
Work station dimensions (W × D × H)	mm	630 × 820 (desktop)/ 1750 (stand-alone) × 670	860 × 1310 × 2000/ 2310	1150 × 1405 × 2000/ 2600	1150 × 1580 × 2010/ 2520
Weight (without laser, supply unit)	kg	82 (desktop)/ 145 (stand-alone)	380	1050	1300
Electrical connection (voltage)	V	100/240	115/230	120/230	120/230
Electrical connection (frequency)	Hz	50/60	50/60	50/60	50/60
Electrical connection (amperage)	A	2.33/5 at 230 V 5.25/10 at 100 V	10/16 at 230 V 20 at 115 V	16 at 230 V 20 at 120 V	16 at 230 V 20 at 120 V
Max. workpiece dimensions (W × D × H)	mm	440 × 350 × 200	680 × 700 × 500	1000 × 650 × 500	Rotary plate Ø 770 mm
Max. workpiece weight	kg	12	50/25 (with X/Y axis)	100/50 (with Y axis)	35 per page
Available axes		Z	X   Y   Z	X   Y   Z	X   Z
Max. traverse path	mm	200	300   300   500	650   350   500	650   500
Rotary axis	mm	65	65, 150	125	125
Suction system		Built-in, external possible	Built-in, external possible	Built-in, external possible	Built-in, external possible

<sup>[1]</sup>Without TruMark 5010 and 5020.

Content subject to change without notice. Only specifications in our offer and order confirmation are binding.

# The passion that drives us

From production and manufacturing technology to laser systems and material processing, we develop highly innovative products and services to meet your needs. Our solutions are superbly reliable and ready for industrial use. We do everything we can to give you a powerful competitive edge, drawing on our expertise, experience, and a genuine passion for what we do.

## Industry 4.0 – solutions for your future

The fourth industrial revolution is changing the world of manufacturing. Is it possible to stay competitive internationally with all this change? Yes – with the opportunities offered by digital networking. With our pragmatic solutions, we will support you every step of the way on your networked manufacturing journey, helping you make your processes more transparent, more flexible and, first and foremost, more cost-effective. This will enable you to make the most of your resources and ensure your production process is fit for the future.

TruConnect is synonymous with Industry 4.0 at TRUMPF. The range of solutions connects man and machine through information while covering all steps of the production process – from quotation through to shipping your parts.



**TruConnect**  
Your Smart Factory



Check out our  
YouTube page:  
[www.youtube.com/  
TRUMPPTube](http://www.youtube.com/TRUMPPTube)



## Lasers for manufacturing technology

Whether on a macro, micro, or nano scale, we can offer you the right laser and the right technology to create an innovative and cost-efficient production environment for any industrial application. We can also provide you with appropriate system solutions, application know-how, and consulting services.

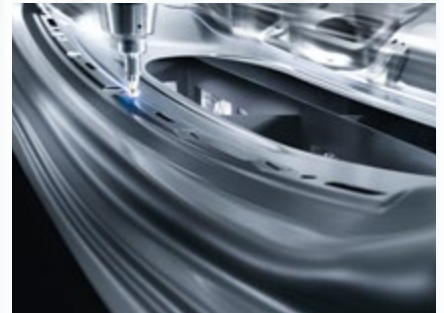

## Power-supply systems for high-tech processes

From semiconductor manufacturing to solar cell production, our MF and RF generators supply electrical power for induction heating-, as well as plasma and laser excitation at a clearly defined frequency and output, with high levels of reliability and repeatability.



## Machine tools for flexible sheet metal and pipe work

From laser cutting and punching to bending and laser welding, we provide our customers with tailor-made machines and automation solutions for a versatile array of sheet machining processes. That includes advice, software, and services – in short, everything you need to achieve reliable production of high-quality products.



TRUMPF is certified to ISO 9001  
(Find out more: [www.trumpf.com/s/quality](http://www.trumpf.com/s/quality))

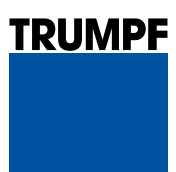

TRUMPF Laser- und Systemtechnik GmbH  
[www.trumpf.com](http://www.trumpf.com)